

Biochemical studies of carbohydrate blood group antigens  
Carbohydrate phenotype in relation to cellular glycosyltransferases

Mette Diswall



UNIVERSITY OF GOTHENBURG

Institute of Clinical Sciences

Department of Surgery

2009

© Mette Diswall, 2009

Institute of Clinical Sciences

Department of Surgery

University of Gothenburg

Printed by Intellecta DocuSys AB

Göteborg, 2009

ISBN 978-91-628-7797-2

# ABSTRACT

The possibility to alter the cell surface carbohydrate expression by insertion or deletion of glycosyltransferase genes is a powerful technique to study the biological function of selected carbohydrate antigens. However, shifting the equilibrium between competing glycosyltransferases might lead to unexpected phenotypic effects, such as accumulation of other carbohydrate antigens and exposure of antigen structures that normally are cryptic or present in minute amounts on the cell surface.

The present work explores the relationship of glycosyltransferase repertoire (genotype) and the resulting cell membrane glycolandscape (phenotype) from a glycosphingolipid perspective using two model systems where glycosyltransferase genes have been deleted or introduced. In addition to contributing to basal glycobiology, the experimental models have the potential to serve clinical purposes in the xenotransplantation and microbial adhesion fields. Glycosylation is not template driven, explaining why the cell membrane carbohydrate expression cannot be predicted from genotyping, but rather requires phenotyping. For phenotyping in this sense, antibody/lectin recognition of cell membrane antigens is insufficient necessitating structural determination.

Neutral and acidic glycolipids from tissues and cells were isolated by means of organic solvent extraction and repeated chromatography steps. Individual glycolipid components were purified by high performance liquid chromatography. The antigenic properties of the glycolipids were examined for reactivity with mono- and polyclonal antibodies, lectins and sera on thin layer chromatography plates. Structural elucidation was conducted by the combined use of mass spectrometry and proton nuclear magnetic resonance spectroscopy.

Our studies report an indisputable correlation between glycosyltransferase gene setup and the resulting glycolandscape phenotype. The study is also indicative of the renowned complexity of glycosylation, *e.g.* the glycosyltransferase dependence on the underlying protein/lipid backbone and the species-, individual- and organ-specific glycosyltransferase activity. In addition, we have identified several novel glycosphingolipids in pig tissues for which function and importance remain to be elucidated.

*Key words:* glycosphingolipid, glycosyltransferase, genetic modification, carbohydrate, mass spectrometry, proton NMR spectroscopy, xenotransplantation, GalT-KO pig

# LIST OF PUBLICATIONS

- I            **Diswall M**, Ångström J, Schuurman H-J, Dor FJ, Rydberg L, Breimer ME. (2007) Studies on glycolipid antigens in small intestine and pancreas of alpha1,3galactosyltransferase knockout miniature swine. *Transplantation* 84(10): 1348-56
- II            **Diswall M**, Ångström J, Schuurman H-J, Dor FJ, Rydberg L, Breimer ME. (2008) Glycolipid studies in small intestine and pancreas of alpha1,3galactosyltransferase knockout miniature swine: alpha1,3GALT-KO animals lack alpha-GAL antigens and contain novel bloodgroup H compounds. *Transplantation Proceedings* 40(2): 543-6
- III           **Diswall M**, Ångström J, Karlsson H, Phelps C, Ayares D, Teneberg S, Breimer ME. Studies of alpha1,3-galactosyltransferase knock-out pig glycolipids and their reactivity with human and baboon antibodies. *Manuscript*
- IV           Löfning J, **Diswall M**, Eriksson S, Borén T, Breimer ME, Holgersson J. (2008) Studies of Lewis antigens and *H. pylori* adhesion in CHO cell lines engineered to express Lewis b determinants. *Glycobiology* 18(7): 494-501

Reprints were made with kind permission from the publishers.









# TABLE OF CONTENTS

<b>ABSTRACT</b> .....	<b>3</b>
<b>LIST OF PUBLICATIONS</b> .....	<b>4</b>
<b>TABLE OF CONTENTS</b> .....	<b>5</b>
<b>ABBREVIATIONS</b> .....	<b>6</b>
<b>THE EUKARYOTIC CELL MEMBRANE</b> .....	<b>7</b>
CELL MEMBRANE CARBOHYDRATES .....	7
ASPECTS ON FUNCTIONS AND ROLES OF GLYCOCONJUGATES.....	9
GLYCAN BIOSYNTHESIS .....	10
<b>GLYCOSPHINGOLIPIDS</b> .....	<b>13</b>
GSL STRUCTURE AND PRESENTATION IN LIPID RAFTS.....	13
NOMENCLATURE .....	14
CARBOHYDRATE BLOOD GROUPS.....	15
DISTRIBUTION OF GSLS.....	17
<b>GLYCAN PHENOTYPE IN RELATION TO GLYCOSYLTRANSFERASE GENOTYPE</b> .....	<b>19</b>
NATURALLY OCCURRING GLYCOSYLTRANSFERASE VARIATIONS.....	20
GENETIC MODIFICATIONS OF GLYCOSYLTRANSFERASES.....	21
GENOTYPE-PHENOTYPE CORRELATIONS ARE DIFFICULT TO ESTABLISH AND IMPOSSIBLE TO PREDICT .....	21
<b>EXPERIMENTAL SYSTEMS USED IN THE PRESENT WORK</b> .....	<b>23</b>
GENETICALLY MODIFIED PIG USED IN XENOTRANSPLANTATION .....	23
Le <sup>B</sup> EXPRESSING CHO CELLS AS A MODEL FOR <i>H. PYLORI</i> INFECTION .....	28
<b>METHODOLOGICAL CONSIDERATIONS</b> .....	<b>31</b>
TISSUE AND CELL SPECIMENS .....	31
ISOLATION AND PURIFICATION OF GSLS.....	31
CHARACTERIZATION OF GSLS.....	33
<b>RESULTS AND DISCUSSION</b> .....	<b>38</b>
$\alpha$ 1,3GALT-KO EFFECTS .....	38
REACTIVITY WITH HUMAN AND BABOON SERUM ANTIBODIES .....	45
GLYCOSYLTRANSFERASE CORE CHAIN DEPENDENCE.....	46
<b>SUMMARY AND FUTURE PERSPECTIVES</b> .....	<b>49</b>
<b>ACKNOWLEDGEMENTS</b> .....	<b>51</b>
<b>REFERENCES</b> .....	<b>52</b>

# ABBREVIATIONS

AVR	Acute vascular rejection
CBA	Chromatogram binding assay
CHO	Chinese hamster ovary
ER	Endoplasmic reticulum
FucT	Fucosyltransferase
Gal	$\alpha$ 1,3-galactosyl
GalT	Galactosyltransferase
Gb3	Globotriaosylceramide
GlcCer	Glucosylceramide
GalCer	Galactosylceramide
GSL	Glycosphingolipid
<i>H. pylori</i>	<i>Helicobacter pylori</i>
H type 1 / type 2	Core type 1 / 2 blood group H compound
HAR	Hyperacute rejection
HD	Hanganutziu-Deicher
HPLC	High performance liquid chromatography
HPTLC	High performance thin layer chromatography
iGb3	Isoglobotriaosylceramide
KO	Knockout
LacCer	Lactosylceramide
LacNAc	N-acetyllactosamine
LC-ESI/MS	Liquid chromatography/ mass spectrometry
Le <sup>a</sup>	Lewis a
Le <sup>b</sup>	Lewis b
Le <sup>x</sup>	Lewis x
Le <sup>y</sup>	Lewis y
NeuAc	N-acetylneuraminic acid
NeuGc	N-glycolylneuraminic acid
nLc4	Neolactotetraosylceramide
NMR	Nuclear magnetic resonance
PGC	Polyglycosylceramide
SiaT	Sialyltransferase
WT	Wildtype

## *Symbolic representations of monosaccharides mentioned in the thesis*

 Galactose (Gal)	 Mannose (Man)
 N-Acetylgalactosamine (GalNAc)	 Xylose (Xyl)
 Glucose (Glc)	 N-Acetylneuraminic acid (Neu5Ac)
 N-Acetylglucosamine (GlcNAc)	 Fucose (Fuc)
 Glucosamine (GlcN)	

# THE EUKARYOTIC CELL MEMBRANE

All cells are bounded by a semipermeable lipid bilayer that constitutes the interface between the interior of the cell (endoplasmic side) and the surrounding fluid (exoplasmic side). As depicted in Figure 1, membrane matrix lipids consist mainly of choline phospholipids (outer layer) and amine phospholipids (inner layer). Cholesterol and membrane proteins are interspersed in the bilayer and the exoplasmic side is covered by a dense layer of glycans. This so-called *glycocalyx* or *glycolandscape* is composed of carbohydrates bound to lipids or proteins. Until the 1970's phospholipids and membrane proteins were believed to be randomly distributed in the cell membrane according to Singer-Nicolson *fluid mosaic model* [1]. Simons and van Meer studied lipid sorting in epithelial cells and observed that certain lipids such as glycolipids were enriched in domains of the plasma membrane [2]. Later Simons and co-authors presented the *lipid raft* model which describes specialized microdomains in the exoplasmic leaflet enriched in cholesterol, glycolipids and selected transmembrane proteins [3].

## Cell membrane carbohydrates

The major forms of membrane-associated glycans found in the plasma membrane in eukaryotic cells are proteoglycans, glycoproteins and glycolipids (outlined in Figure 1). *Proteoglycans* are heavily glycosylated proteins composed of a core protein with one or more covalently attached glycosaminoglycan chains. The long, linear glycan chains are negatively charged under physiological conditions due to the presence of sulfate and uronic acid groups and occur mainly in the extracellular matrices of connective tissues but can also be membrane bound [4]. The oligosaccharide unit of *glycoproteins* can be attached to the cell membrane via a protein or phosphatidylinositol-containing glycolipids. The most common types of protein-linked glycans are the N-glycans where the oligosaccharide is covalently attached to the amide nitrogen of asparagine [5] and the O-glycans where the carbohydrate is linked to the oxygen of the side chain of asparagine or threonine in the peptide chain [6].

*Glycolipids* are of the glycoacylglycerol or the glycosphingolipid (GSL) type. The former type is comprised of a glycan chain covalently linked to one or more glycerol hydroxyl groups whereas in the latter the glycan is covalently attached to the primary hydroxyl group of ceramide. GSLs are the focus of this thesis and their structures are described in more detail below.

Glycan chains are assembled from simple monosaccharides linked to one another via glycosidic linkages to any one of several positions on another monosaccharide in the chain. Glycosidic linkages exist in either  $\alpha$ - or  $\beta$ -configurations. Altogether, a glycan chain of merely three monosaccharides can in theory adopt nearly 28,000 combinations; however, the number of biologically relevant glycan conformations is much smaller.

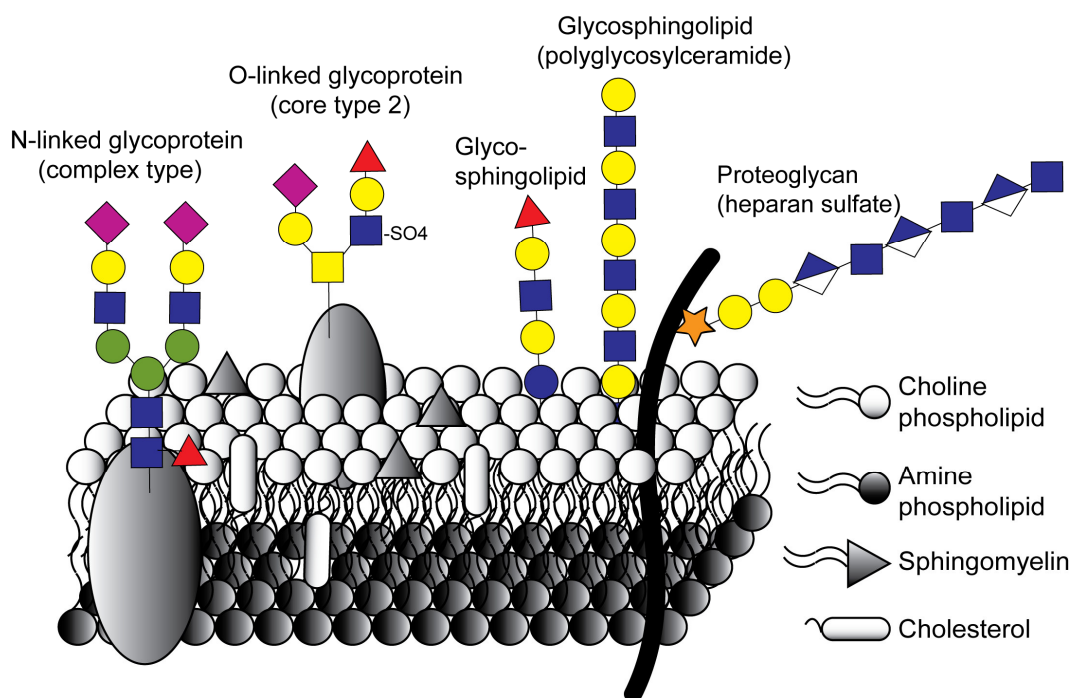

**Figure 1.** Schematic model of a mammalian plasma membrane. Symbolic presentation of monosaccharides is as recommended by the Consortium for Functional Glycomics (see page 6).



## Aspects on functions and roles of glycoconjugates

*Carbohydrate-protein interactions* are characterized by low affinity interactions, often with  $K_d$  values in the  $\mu\text{M}$  to  $\text{mM}$  range. The low affinity is compensated for by multivalent interactions of multiple glycan binding proteins with their ligands, which increases the effective avidity, reviewed in [7]. The low affinity, multivalency and avidity of carbohydrate-protein interactions is the basis of the complex and highly regulated interplay between glycans and proteins and are considered to contribute to the fine-tuning of biological processes, as compared to protein-protein interactions which rather function as “on and off” switches.

The biological roles of glycans range from being seemingly disposable to absolutely essential and can be classified into two broad categories; i) structural and modulatory properties and ii) specific recognition of glycans by surrounding molecules. The second category may be subdivided in intrinsic and extrinsic interactions. Intrinsic functions include interactions of carbohydrates with glycan binding proteins (*i.e.* lectins) in cell-cell interactions, recognition of extracellular molecules or interactions between glycans on the same cell. One of the best characterized examples is the binding of P selectin on endothelial cells to sialyl Lewis x ( $\text{Le}^x$ ) on P-selectin glycoprotein ligand 1 (PSGL-1) during recruitment of leukocytes to sites of infection and inflammation [8]. Another striking example is the Notch signalling receptor, whose activation by ligand binding is modulated by modification of O-glycans [9].

Extrinsic interactions include the recognition of glycan receptors by microbial adhesins, agglutinins and toxins [10]. Examples include the GSL globotriaosylceramide (Gb3) as receptor for shiga- and verotoxin [11], the GM1 ganglioside as receptor for cholera toxin [12], the blood group P1 antigen and other  $\text{Gal}\alpha\text{4Gal}$ -structures as receptors for pyelonephritic strains of *E. coli* [13] and the fucosylated blood group antigens H type 1, Lewis b ( $\text{Le}^b$ ) and sialylated dimeric  $\text{Le}^x$  as receptors for *Helicobacter pylori* (*H. pylori*). The carbohydrate binding of *H. pylori* is further addressed in *paper IV*.

## Glycan biosynthesis

The stepwise synthesis of glycans is mediated by the action of enzymatically active *glycosyltransferases*. Thus the glycosyltransferases are the primary gene products and the glycans are the secondary gene products. Most glycosylation takes place in the endoplasmic reticulum (ER) and Golgi apparatus, but nuclear and cytoplasmic glycosylation also occurs. GSL and glycoproteins often share many similarities in the terminal carbohydrate sequences, whereas core structures close to the protein or lipid carrier vary [14]. N-glycan synthesis is initiated in the ER by assembly of the oligosaccharide on a lipid carrier. The oligosaccharide is transferred to the polypeptide chain (“*en bloc*”) and is thereafter processed and remodelled in the ER. Further glycosylation occurs in the Golgi apparatus. O-glycans are formed by stepwise addition of glycans in the Golgi apparatus. The ceramide used in GSL biosynthesis is synthesized on the cytoplasmic surface of ER and is thereafter transferred by specific membrane transporters (“flippases”) to the ER lumen where the active center of galactosylceramide (GalCer) synthase is localized [15]. Further glycosylation occurs in Golgi apparatus. The structural similarities between terminal sequences of glycoproteins and GSLs indicate that the terminal glycan sequences are synthesized by common glycosyltransferases [14].

### *Glycosyltransferases*

Most Golgi-localized glycosyltransferases are type II membrane proteins comprising a short N-terminal cytoplasmic tail, a transmembrane domain, a stem region and a large luminal enzymatically active domain [16]. More than 240 human glycosyltransferases have been cloned to date and are spread across more than 60 families, classified on the basis of their specificity for the donor sugar they transfer and the linkage they create. It was previously believed that one glycosyltransferase could merely synthesize one glycosidic linkage, but there is now increasing evidence of several glycosyltransferases creating the same glycosidic linkage on the same precursor but with different efficiency, and conversely of glycosyltransferases being able to catalyze several different glycosidic linkages [17]. Many factors contribute to structural determination of glycoconjugates at particular glycosylation sites, such as localization

and regulation of glycosyltransferases, precursor competition, mechanisms of catalysis and specificity for donor and acceptor sugars [18].

### *Glycosyltransferase localization*

The view that glycosyltransferases acting early in glycosylation are localized in the *cis* or *medial* Golgi compartments whereas enzymes acting later in the pathway are found in the *trans* Golgi cisternae and *trans* Golgi network is tempting but hugely simplified. Most glycosyltransferases are distributed in overlapping gradients in the Golgi apparatus and use multiple mechanisms to adopt and maintain their sub-Golgi localization [19]. The mechanisms determining localization have been studied by purification, cloning and characterization of Golgi enzymes [20], analysis of glycosyltransferase mutants [21, 22] and using specific inhibitors of the glycosylation pathways.

Glycosyltransferases characterized to date share little or no amino acid sequence identity arguing that a common Golgi retention sequence is unlikely. The transmembrane region as well as the flanking domains of type II Golgi resident glycosyltransferases have been identified to maintain Golgi retention in some cases [23-25]. The *bilayer thickness hypothesis* proposes that glycosyltransferases localize in Golgi compartmental regions with a membrane thickness to match the length of their transmembrane domains, irrespective of amino acid composition [26]. The model relies on the observation that cholesterol increases the width of a lipid bilayer, and that cholesterol concentration increases in the *cis* to *trans* direction of the Golgi stack. The highest concentration is observed in the plasma bilayer and plasma membrane proteins also appear to have longer transmembrane regions than Golgi enzymes [27, 28]. However, numerous studies have shown that the length of the transmembrane domain does not fully account for Golgi localization and retention [29].

In the *oligomerization/kin recognition model* glycosyltransferases are suggested to form homo- or heterooligomers through interactions between their transmembrane and luminal sequences upon arrival at the appropriate compartment. This prevents them

from entering vesicles for anterograde or retrograde transport [30] and also increases the efficiency of the stepwise assembly of monosaccharides. The model is supported by the finding that some transferase pairs that catalyze sequential reactions co-localize in specific Golgi compartments and co-precipitate from cell extracts. Also, experiments replacing the cytoplasmic tails of *medial*-Golgi resident transferases with an ER-retention signal have shown that the chimeric transferase was localized in the ER and formed a stable complex with ER-localized wildtype (WT) enzyme [31]. Oligomerization is suggested to occur amongst medial but not late acting Golgi transferases [32, 33]. Merely the formation of high molecular weight complexes does not prevent movement through the secretory pathway since *e.g.* collagen appear to be readily transported through Golgi [34].

Importantly, models describing sub-Golgi localization of glycosyltransferases are not mutually exclusive but rather believed to act in concert with other, known as well as unknown, mechanisms. It should be emphasized that observations made with one enzyme or cell type does not necessarily apply to other enzymes or cell types, or the situation *in vivo*. Fusion of the glycosyltransferase to a reporter protein or studies on chimeric proteins may also affect the localization and expression level of the enzyme.

# GLYCOSPHINGOLIPIDS

The work in the present thesis focuses on studies of the carbohydrate moiety of GSLs. However, many of the concepts discussed also apply to protein-bound carbohydrates.

## GSL structure and presentation in lipid rafts

Johann Thudichum is considered the father of sphingolipid research for his pioneering work during the second half of the 19<sup>th</sup> century. Among other achievements he isolated the monoglycosylceramide GalCer from human brain [35]. These novel molecular players were named sphingolipids after the Egyptian Sphinx because of the difficulty of isolation and their, at that time, unknown functional roles.

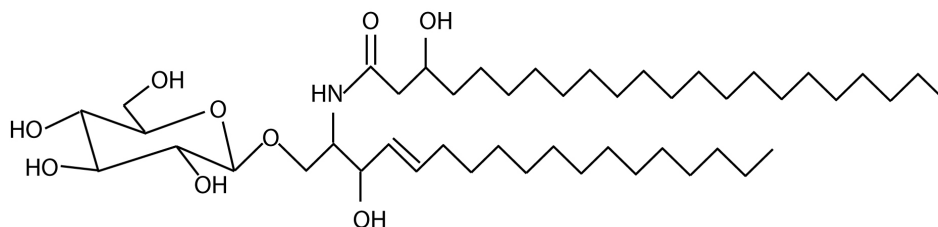

**Figure 2.** *Glucosylceramide with d18:1 sphingosine and h22:0 fatty acid.*

The amphipatic GSLs comprise a polar glycan head group linked to a non-polar ceramide and are generally localized in the exoplasmic leaflet of the plasma membrane bilayer with the hydrophobic ceramide embedded in the membrane and the hydrophilic glycan protruding away from the cell into the extracellular space [36]. The ceramide consists of a long chain base amide-linked to a fatty acid (Figure 2). Hence, there are three levels of variability of a GSL: the glycan, the long chain base and the fatty acid. All three variables may differ between GSLs from different species, cells and tissues. In mammals the d18:1 long chain base (sphingosine) is the most common and the fatty acids typically consist of 18-25 carbons.

A correlation has been established between the degree of hydroxylation of the ceramide and the chemical and physical stress the plasma membrane is exposed to [37]. Extensive hydrogen bond formation confers a stabilizing effect on the membrane and is proposed to account for the formation of lateral microdomains containing *e.g.* sphingolipids, cholesterol and specialized membrane proteins [38]. These microdomains serve as organizing centers for the assembly of signaling molecules, influence membrane fluidity and trafficking, and regulate neurotransmission [39]. About a decade ago the concept of a particular form of microdomains termed glycosynapses was developed [40]. In these microdomains GSLs are clustered with signal transducers, adhesion receptors or growth factors. Functional roles of these are indicated as carbohydrate-dependent adhesion creates a signal that is transmitted to the nucleus, reviewed in [41].

## Nomenclature

GSLs are commonly divided into neutral and acidic GSLs. Acidic GSLs are further subdivided into gangliosides (sialic acid containing GSLs) and sulfatides (sulfate ester conjugated GSLs). Moreover, GSLs are classified on the basis of differences in their carbohydrate core structures. The most commonly occurring cores, or roots, in mammalian GSLs are summarized in Table 1. Core chains can be further elongated and generate a wide array of different carbohydrate structures such as the histo-blood group antigens. In this thesis the nomenclature, systemic names and abbreviations recommended by IUPAC/IUBMB (<http://www.chem.qmul.ac.uk>) are obeyed and symbolic presentation of monosaccharides employed in figures is as recommended by the Consortium for functional glycomics (<http://www.functionalglycomics.org>), outlined on page 6.

**Table 1.** Root (core) structures of common mammalian GSLs.

Root	Symbol	Root structure
1a) Lacto	Lc	Gal $\beta$ 3GlcNAc $\beta$ 3Gal $\beta$ 4Glc $\beta$ 1-Cer
b) Neolacto	nLc	Gal $\beta$ 4GlcNAc $\beta$ 3Gal $\beta$ 4Glc $\beta$ 1-Cer
2a) Ganglio	Gg	Gal $\beta$ 3GalNAc $\beta$ 4Gal $\beta$ 4Glc $\beta$ 1-Cer
b) Isoganglio	iGg	Gal $\beta$ 4GalNAc $\beta$ 4Gal $\beta$ 4Glc $\beta$ 1-Cer
3a) Globo	Gb	GalNAc $\beta$ 3Gal $\alpha$ 4Gal $\beta$ 4Glc $\beta$ 1-Cer
b) Isoglobo	iGb	GalNAc $\beta$ 3Gal $\alpha$ 3Gal $\beta$ 4Glc $\beta$ 1-Cer
4. Gala	Ga	Gal $\alpha$ 4Gal $\beta$ 1-Cer
5. Muco	Mc	Gal $\beta$ 4Gal $\beta$ 4Glc $\beta$ 1-Cer

## Carbohydrate blood groups

The glycan core structures in Table 1 can be further elongated by addition of monosaccharides in various combinations. Among other elaborations, the specific carbohydrate sequences representing the *blood group systems* are created (Table 2). Karl Landsteiner's observation in the beginning of the 20<sup>th</sup> century that sera from some individuals agglutinated red blood cells from other individuals [42] eventually led to the classification of the ABO blood group system [43, 44]. The term *histo-blood group antigens* was introduced by Clausen and Hakomori and refers to carbohydrate antigens of both glycoprotein and GSL nature that are present in most cells and tissues [45]. Antibodies directed towards antigens lacking on an individual's own cells are believed to form early during childhood as an immunologic response to *e.g.* gastrointestinal bacteria expressing these carbohydrate epitopes, and is the basis for the self/non-self discrimination of the immune system.

**Table 2.** Carbohydrate blood group systems discussed in this thesis. The systems are of both glycoprotein and GSL nature, except the P blood group antigens (marked with asterisk) which have only been found on GSLs.

<i>Antigen</i>	<i>Structure</i>
ABH system	
H	Fuc $\alpha$ 2Gal $\beta$ -R
A	GalNAc $\alpha$ 3Fuc $\alpha$ 2Gal $\beta$ -R
B	Gal $\alpha$ 3Fuc $\alpha$ 2Gal $\beta$ -R
Lewis system	
Le <sup>a</sup>	Gal $\beta$ 3(Fuc $\alpha$ 4)GlcNAc $\beta$ -R
Le <sup>b</sup>	Fuc $\alpha$ 2Gal $\beta$ 3(Fuc $\alpha$ 4)GlcNAc $\beta$ -R
Le <sup>x</sup>	Gal $\beta$ 4(Fuc $\alpha$ 3)GlcNAc $\beta$ -R
Le <sup>y</sup>	Fuc $\alpha$ 2Gal $\beta$ 4(Fuc $\alpha$ 3)GlcNAc $\beta$ -R
P system*	
P <sup>k</sup>	Gal $\alpha$ 4Gal $\beta$ 4Glc $\beta$ 1-Cer
P	GalNAc $\beta$ 3Gal $\alpha$ 4Gal $\beta$ 4Glc $\beta$ 1-Cer
P1	Gal $\alpha$ 4Gal $\beta$ 4GlcNAc $\beta$ 3Gal $\beta$ 4Glc $\beta$ 1-Cer
Ii system	
i	Gal $\beta$ 4GlcNAc $\beta$ 3Gal $\beta$ 4GlcNAc $\beta$ 3Gal $\beta$ -R
I	Gal $\beta$ 4GlcNAc $\beta$ 6(Gal $\beta$ 4GlcNAc $\beta$ 3)Gal $\beta$ -R
Gal $\alpha$ 3	Gal $\alpha$ 3Gal $\beta$ 4GlcNAc $\beta$ 3-R



## Distribution of GSLs

GSLs are ubiquitously distributed among all eukaryotic species and are also found in some bacteria. The expression of GSLs varies considerably between *e.g.* different species, individuals, strains and organs.

### *Species and strain variation*

Numerous comparative studies have shown that GSL expression varies both quantitatively and qualitatively between different species [46, 47]. GSLs isolated from the same tissue, such as small intestine [48] and erythrocytes [49] from different species show considerably different GSL patterns. Interestingly GSL composition also varies between different strains of the same species [50-52]. The species variation is the basis for the immunological barrier leading to graft destruction in xenotransplantation (*papers I-III*).

### *Individual, organ and cell distribution*

The polymorphism of glycosyltransferase genes partly explains the varying glycan expression in different individuals of the same species [45, 53]. Histo-blood group antigens of GSL nature are expressed in most mammalian epithelial cells with a distinct distribution between specific cell types and tissues, reviewed by Ravn and Dabelsteen [54]. The main factors responsible for variation are the blood group ABH, *Lewis (Le)* and *Secretor (Se)* gene status of the individual, the epithelial cell type and the cellular differentiation status. The type 1 GSLs (lacto-series) are synthesized in ectodermal tissues such as small intestinal mucosa and glandular epithelium [47]. Type 2 GSL chain GSLs (neolacto-series) are expressed in tissues of ectodermal and mesodermal origin such as skin and erythrocytes and in some endodermal tissues. Erythrocytes are also one of the richest source in type 4 carbohydrate chains (globo-series), also found in *e.g.* kidney, small intestine, liver and heart [55].

A remarkable example of the differential distribution of GSLs within the same organ is white and grey matter of the brain. Myelin-rich white matter is abundant in GalCer and sulfatide whereas grey matter contains a higher amount of gangliosides [56].

Furthermore, the apical and basolateral regions of polarized cell types such as epithelial cells differ in GSL composition [57, 58]. The differential distribution of GSLs in different organs necessitates characterization of multiple organs in an experimental model (*papers I-III*).

### *Developmental and pathological variation*

Malignant transformation of cells is linked to distinct alterations of glycan profiles [59, 60]. Some GSLs are abundantly expressed in normal cells and reduced or deleted in transformed cells [61] and conversely, some GSLs are increased in certain types of tumors such as sialyl Le<sup>a</sup> in gastrointestinal and pancreatic tumors [62], sialyl Le<sup>x</sup> in gastrointestinal, breast and lung tumors [63] and the dimeric “Le<sup>a</sup>-on-Le<sup>a</sup>” and “sialyl Le<sup>x</sup>-on -Le<sup>x</sup>” GSLs in *e.g.* colorectal cancer [64-67]. Interestingly, blood group A-like antigens have been isolated from stomach cancer tumors of blood group O and B individuals [68] and the xenogeneic Forssman and N-glycolylneuraminic acid (NeuGc) antigens have been identified in various human tumors [69]. Some of these antigens are of oncofetal nature, meaning that their synthesis is repressed during development and de-repressed in tumors by as yet unknown mechanisms [70].

# GLYCAN PHENOTYPE IN RELATION TO GLYCOSYLTRANSFERASE GENOTYPE

*"It takes all the running you can do, to keep in the same place. If you want to go somewhere else, you must run twice as fast as that."* declared The Red Queen in Lewis Carroll's *Through the Looking-Glass* [71]. The necessity for the individual to change in order to keep up with a changing environment is a central theme in glycobiology. The glycan repertoire balances between the intrinsic requirements for carbohydrates that are essential for cellular functions, and the microorganismal abuse of these for binding and invading host cells [72]. This may explain the remarkable structural variations of glycans in biology, which contribute to species diversity and perhaps even to the development of novel species. Approaches for understanding the biological functions of glycans include inhibition of specified steps in the glycosylation pathways. The consequences of such manipulations cannot however, be predicted *a priori*. There are many examples of secondary glycosylation effects resulting from genetic modifications of glycosyltransferases. The examples presented below focus on the GSL phenotypic effects, although similar alterations in glycoprotein repertoire are also likely to occur.

GSLs are proposed to be essential for the intercellular coordination of multicellular organisms, but disposable at the single cell level. This is based on the observations that i) cultured mouse cells completely deficient in glucosylceramide (GlcCer) synthase activity showed normal growth and survival [73] and ii) the knockout of the gene for GlcCer synthase in mice resulted in embryonic lethality during gastrulation between embryonic day 6.5 and 7.5 [74]. Further insight into the function of GlcCer synthase in brain development was obtained when neural cell type-restricted disruption of the GlcCer synthase was performed. The modification did not affect embryonic development, mice died however, at about 3 weeks of age, which indicated that GSLs are essential for postnatal brain maturation [75].

## Naturally occurring glycosyltransferase variations

There are several examples of glycosyltransferases compensating for one another when a specific transferase is defect or lacking. Selected examples are briefly outlined below.

The ABO and Lewis blood group systems account for some of the most well-established glycosyltransferase mutations and provide numerous examples of enzymes competing for common precursors. A striking example is the elongation of the blood group H precursor by the *Le* gene encoded  $\alpha$ 1,3/4FucT to form the  $Le^b$  hexasaccharide in blood group O individuals. In blood group A and B individuals  $\alpha$ 1,3GalNAcT and  $\alpha$ 1,3GalT, respectively, compete with  $\alpha$ 1,3/4-FucT for the H precursor causing a weak or absent  $Le^b$  expression despite the presence of *Le* and *Se* genes.  $\alpha$ 1,3/4FucT can utilize the blood group A and B compounds to synthesize  $ALe^b$  and  $BLe^b$  epitopes, but  $\alpha$ 1,3GalNAcT and  $\alpha$ 1,3GalT cannot act on  $Le^b$  [76-79].

Another example from transfusion biology is individuals of the rare p phenotype, which lack the  $\alpha$ 1,4GalT ( $P^k$  transferase) that normally produces Gb3. Affected individuals are thus unable to synthesize Gb3, globoside or downstream biosynthetic determinants [80]. Accumulation of lactosylceramide (LacCer), as well as increased levels of neolactotetraosylceramide (nLc4) and  $Le^x$  pentaglycosylceramide is indicative of a compensatory effect resulting from the metabolic block of the globo-series biosynthetic pathway.

The first report of a disruption of ganglioside biosynthesis associated with human disease was the loss-of-function mutation of GM3 synthase in infantile-onset symptomatic epilepsy syndrome [81]. Affected individuals lacked GM3 and downstream biosynthetic GSLs completely, whilst the precursor LacCer and GSLs of the globo- and neolacto-series had accumulated. In analogy with this finding the reduced activity of GM3 synthase observed in a human melanoma cell line also resulted in accumulation of LacCer [82].

## Genetic modifications of glycosyltransferases

GalCer synthase knockout mice were as expected unable to synthesize GalCer and sulfatide. Increased levels of GlcCer were observed in the myelin sheath, partly compensating for the loss of GalCer and sulfatide [83, 84]. The myelin had a grossly normal ultrastructural appearance but alterations of the paranodal and periaxonal myelin domains resulted in electrophysiological deficits in the central and peripheral nervous systems from about postnatal day 12-16 and mice developed severe tremor and hindlimb paralysis [85]. Similarly, a GM3 synthase knockout mouse strain completely lacked GM3 and downstream gangliosides whilst gangliosides of the competing ganglioside series (o-series) had accumulated. The mice suffered from enhanced insulin sensitivity but had an otherwise normal phenotype [86].

A transgenic mouse model expressing Le<sup>b</sup> was established to study the molecular events following Le<sup>b</sup> mediated adhesion of *H. pylori* to gastric epithelium [87, 88]. Three novel GSL structures were isolated: Le<sup>b</sup>-like hexaglycosylceramide on ganglio core, isoglobotriaosylceramide (iGb3) with an internal blood group B determinant, and elongated fucosyl-gangliotetraosylceramide [88]. The synthesis of the latter two GSLs was not believed to be due to the genetic modification *per se* as no  $\alpha$ 3- or  $\alpha$ 4-linked fucoses were present in these compounds, but may, however, reflect an overall change in the GSL pattern upon disturbance of the glycosyltransferase repertoire.

## Genotype-phenotype correlations are difficult to establish and impossible to predict

Transgenic incorporation or knockout of glycosyltransferase genes in cells or organisms give mixed results depending on the glycosyltransferase targeted and the cell type used. In general, modification of glycosyltransferases that act early in the ER/Golgi pathway and are necessary for biosynthesis of core structures, will lead to more severe abnormalities or embryonic lethality compared to when glycosyltransferases acting later in the biosynthesis, and are involved in synthesis of

terminal epitopes, are modified. The *genetic background*, meaning all other genes in an organism, differs between species and individuals and provides an explanation for the differential effect of genetic modifications in two different organisms, such as the two independent GM2/GD2 synthase knockout mouse strains of which one suffered from lethal audiogenic seizures [89], whereas mice from the other strain had a milder phenotype [90].

# EXPERIMENTAL SYSTEMS USED IN THE PRESENT WORK

Much of our understanding of mammalian glycobiology has been obtained and extrapolated from studies of less complex organisms. In the present work we have used two model systems as experimental windows where we have studied the effect of genetic modifications of glycosyltransferase genes on the glycolandscape. In addition to contributing to basal glycobiology, the experimental models have potential to serve clinical purposes in the *xenotransplantation (papers I-III)* and *microbial adhesion (paper IV)* fields.

## Genetically modified pig used in xenotransplantation

Clinical transplantation of organs between individuals of the same species (allotransplantation) is at present the effective therapy to cure patients with end-stage organ failure. However, the demand for organs from patients on the transplant waiting lists are not by far met by the supply of donated organs. Therefore xenotransplantation, meaning transplantation of organs between different species, is explored as a potential alternative to allotransplantation [91].

### *General aspects on xenotransplantation*

Pig is considered the most suitable donor in xenotransplantation for several reasons. It is easy to maintain and breed, reproduces in large litters, organs are appropriate in size and ethical objections are less for pig than for nonhuman primates such as chimpanzee.

The type of rejection a graft encounters depends on whether the transplantation is *concordant* or *discordant*. Concordant transplantation refers to transplantation between phylogenetically related species such as nonhuman primates and humans and the rejection response is similar to that observed in allotransplantation. Discordant transplantation refers to non-related species such as pigs and humans and gives rise to

a rapid and violent response, termed *hyperacute rejection* (HAR) due to preformed antibodies that bind to antigens present in the transplanted organ [92]. HAR occurring in xenorejection has many similarities with HAR encountered in ABO incompatible allotransplantation [93].

### *The Gal $\alpha$ 3 antigen/antibody barrier*

The initiating event of HAR is the binding of human preformed antibodies to the carbohydrate epitope Gal $\alpha$ 3Gal $\beta$ 4GlcNAc-R (Gal $\alpha$ 3 antigen, Galili antigen) in pig tissues.  $\alpha$ 1,3GalT primarily converts N-acetyllactosamine (LacNAc) but is also able act on other core chain types such as Gb3 [57, 94] and Le<sup>x</sup> [95]. Gal $\alpha$ 3 expression on GSLs and glycoproteins appears to be ubiquitous in pigs [96] and the highest expression levels are reported in vascular endothelium, kidney proximal tubules, bronchioli and alveoli [97].

The Gal $\alpha$ 3 antigen is expressed by New World primates and many nonprimate mammals, but is absent from cells and tissues of Old World primates including humans due to an inactivation of the gene encoding the  $\alpha$ 1,3GalT [98]. In agreement with Landsteiner's principle [42] species lacking the Gal $\alpha$ 3 epitope express natural anti-Gal antibodies in serum [99], likely because of immunization through exposure to gastrointestinal microbial antigens similar or identical to the Gal $\alpha$ 3 epitope.

Anti-Gal antibodies are produced by B-cells and are of IgM, IgG and IgA type (IgM>IgG>IgA), constituting approximately 4% and 1% of the total human IgM and IgG pools, respectively [100]. Upon binding of anti-Gal Abs to Gal $\alpha$ 3 antigens on pig graft endothelium complement activation is initiated through the classical pathway (Figure 3).



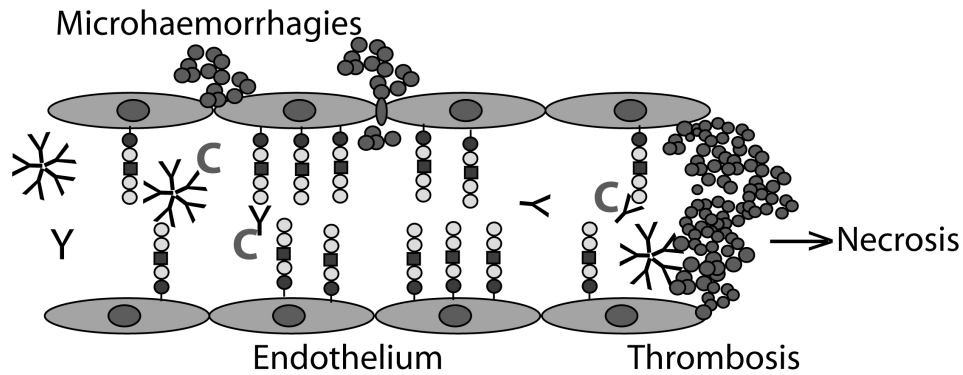

**Figure 3.** HAR is initiated by recipient preformed antibodies (mainly IgM and IgG) directed against Gal $\alpha$ 3 antigens on pig endothelial cells. Antibody binding activates complement and mediates cell injury, microthrombosis and subsequent graft necrosis.

### *Strategies to overcome HAR*

Many different attempts have been tried in order to realize pig-to-human xenotransplantation, either by altering the recipient immune response or by modifying the donor. Methods for removing anti-Gal antibodies include depletion of total plasma proteins by plasmapheresis [101, 102], removal of IgG and IgM by non-specific antibody adsorbents [103] or specific removal of anti-Gal Ig by immunoabsorption on Gal $\alpha$ 3Gal-affinity columns [104]. Also, injecting the patient with soluble saccharides containing the Gal $\alpha$ 3Gal epitope to neutralize anti-Gal antibodies have been tried [105, 106] as well as injecting soluble complement inhibitors such as cobra venom factor or soluble complement receptor type 1 to inhibit the receptor complement cascade [107].

A strategy to reduce Gal $\alpha$ 3 antigens on pig cells was transgenic expression of human  $\alpha$ 1,2FucT to compete with  $\alpha$ 1,3GalT for their common substrate LacNAc. The strategy was successful in mice and resulted in a 90% reduction of Gal $\alpha$ 3 on the cell surface [108-110] whilst the reduction in pig was only about 50% and cells were still subject to lysis in cytotoxicity assays [111]. Transgenic mice and cultured porcine cells were produced that expressed human  $\alpha$ -galactosidase in order to cleave terminal Gal $\alpha$ 3 antigens, however only a partial reduction was reported. Co-expression of  $\alpha$ -

galactosidase and human  $\alpha 1,2\text{FucT}$  resulted in a 99% reduction of terminal  $\text{Gal}\alpha 3$  *in vitro* but this technology was never developed to whole animal experiments [112]. Since the complement system plays an essential role in HAR pigs expressing human complement regulators such as decay accelerating factor (DAF, CD55) or membrane co-factor protein (MCP, CD46) [113] or protectin (CD59) [114] have been produced. Although grafts from these pigs did not undergo HAR they were not protected from later rejection mechanisms such as acute vascular rejection (AVR) [115].

### *$\alpha 1,3\text{GalT-KO}$ pig*

The gene encoding  $\alpha 1,3\text{GalT}$  was successfully deleted in a mouse model as early as 1996 [116]. Mice developed cataracts but were otherwise healthy. Since Galili reported that pig cells express about 500 times the number of  $\text{Gal}\alpha 3$  epitopes than does the mouse it was doubted whether the latter would develop properly without expression of  $\text{Gal}\alpha 3$  antigens [117]. The nuclear transfer technique was not available for large animals such as pigs until fairly recently when two different groups reported the production of healthy  $\alpha 1,3\text{GalT}$  knockout (KO) pigs [118, 119]. Expectations were high when the first pre-clinical  $\alpha 1,3\text{GalT-KO}$  pig-to-nonprimate transplantation trials were performed. The initial experience showed that HAR was overcome. Kidney co-transplanted with thymus had a survival time of up to 83 days [120] and heterotopic cardiac transplantation had a survival time of up to 179 days [121]. However, survival times are only slightly pro-longed compared to the 113 days reported in the CD46 transgenic pig heart to baboon setting where  $\text{Gal}\alpha 3$ -positive pigs were used [122, 123].

At present it is not clear whether the thrombotic microangiopathy seen in rejected  $\alpha 1,3\text{GalT-KO}$  pig tissues is due to the immune system or to molecular incompatibilities between the pig and primate coagulation system [121, 124]. Preformed or elicited antibodies were not detected and the mixed lymphocyte reaction remained unresponsive. Nevertheless, focal Ig and complement deposition were observed in the grafted hearts suggesting that an immune response was involved. This indicates that antigens other than  $\text{Gal}\alpha 3$  contribute to organ rejection and the umbrella

term *non-Gal antigens* is used for these as yet unknown protein and/or carbohydrate antigens.

*The quest for the elusive non-Gal antigens from a carbohydrate perspective*

The priority in the xenotransplantation field in the “post Gal $\alpha$ 3 era” is focused on identifying non-Gal antigens that may be targets for preformed or induced human antibodies. As HAR is overcome the present goal is identification of xenoantigens involved in later stages of rejection. A number of non-Gal glycans have been proposed, such as iGb3, Forssman, LacNAc and NeuGc-containing carbohydrates. However, Buhler *et al.* reported that terminal Gal $\alpha$ , GalNAc $\alpha$ , Gal $\beta$  and N-Hex residues were not involved in anti-non-Gal antibody binding since porcine erythrocytes treated with the respective exoglycosidases in the presence of soluble Gal $\alpha$ 3 trisaccharide did not affect baboon serum antibody binding [125]. Potential non-Gal antigens and their possible involvement in antibody recognition are addressed in *papers I-III*.

## A Le<sup>b</sup> expressing CHO cell line as a model for *H. pylori* infection

The cloning of the majority of known glycosyltransferases and the ability to express these in different cells have made engineering of specific glycans in well-characterized cell lines possible. Chinese hamster ovary (CHO) cells are often preferred for production of recombinant therapeutic glycoproteins and in glycosylation engineering. CHO cells have been widely employed to study mammalian carbohydrate functions and are useful when characterizing cell membrane expression of novel glycosyltransferase genes. These cells have a well established glycan repertoire and a relatively limited number of endogenous glycosyltransferases. They do not express any  $\alpha$ 2,6-SiaTs [126],  $\alpha$ 1,2- or  $\alpha$ 1,3-FucTs [127] or other transferases of the blood group family [128, 129]. O-glycans are merely core 1 based [130, 131], and N-glycans are predominantly complex-type with only type 2 core [132]. The GSL repertoire in CHO cells is dominated by GM3, LacCer and low levels of GlcCer.

*H. pylori* has evolved to recognize specific carbohydrates on host cells [10]. The gram-negative, spiral-shaped bacterium was first isolated from human stomach mucosa by Warren and Marshall in 1984 [133]. Today *H. pylori* infection is considered the world's most common infection, affecting about 50% of the human population. Most often the infection is asymptomatic, however about 10% of the affected individuals develop symptoms such as gastritis, gastric and duodenal ulcers and stomach cancer [134, 135]. *H. pylori* survives low pH, and has thereby created a niche in the hostile environment of the stomach [136]. Binding of *H. pylori* to host cells is mediated by bacterial membrane proteins called adhesins. Two adhesins have been described in *H. pylori*; SabA [137] and BabA [138]. SabA binds to sialylated dimeric Le<sup>x</sup> structures [137] and BabA is specific for the fucosylated blood group antigens H type 1 and Le<sup>b</sup> on *e.g.* gastrointestinal epithelial cells [138, 139].

A cell line expressing Le<sup>b</sup> may serve a useful *in vitro* model for molecular and cell biological studies of *e.g.* Le<sup>b</sup>-mediated *H. pylori* adhesion to host cells. Synthesis of the Le<sup>b</sup> epitope requires the concerted action of several glycosyltransferases. H type 1

is synthesized from the type 1 precursor by the action of  $\alpha$ 1,2FucT (encoded by the *Se* gene). Thereafter  $\alpha$ 1,3/4FucT (encoded by the *Le* gene) adds a second fucose thus forming the Le<sup>b</sup> epitope. Since CHO cells rapidly reach confluence, have a well-defined glycosyltransferase repertoire and are well-characterized from a regulatory point of view, they were the model system of choice for producing the Le<sup>b</sup> epitope for studies of BabA positive *H. pylori* (*paper IV*).

# OBJECTIVES

Altering the cell surface carbohydrate antigen expression by genetic modification of glycosyltransferase genes can be used to study the biological function of selected carbohydrate antigens. However, disrupting the balance between competing glycosyltransferases may lead to unexpected phenotypic effects, such as increased levels of other carbohydrate antigens and exposure of antigen structures that are normally cryptic on the cell surface. The *general aim* of this thesis was to correlate the carbohydrate phenotype with the cellular glycosyltransferases using a knockout pig model and transfected CHO cells.

The *specific questions* we aimed to address were:

Does the  $\alpha$ 1,3GalT-KO in pig

- i) eliminate all Gal $\alpha$ 3-terminated GSL antigens?
- ii) produce new, compensatory GSL antigens?
- iii) affect the human and baboon immune response towards porcine xenografts?

Does transfection of CHO cells

- i) mediate synthesis of lipid- and protein-linked Lewis antigens?
- ii) produce cells that may be used as *in vitro* tools for *H. pylori* infection studies?

# METHODOLOGICAL CONSIDERATIONS

## Tissue and cell specimens

Small intestine and pancreas were obtained from  $\alpha$ 1,3GalT-KO and WT miniature swine [119] whereas heart and kidney were obtained from  $\alpha$ 1,3GalT-KO pigs from a different strain [118]. Knockout of the gene encoding  $\alpha$ 1,3GalT (*GGT1*) was in both strains accomplished by means of nuclear transfer which resulted in pigs where one allele of the locus was knocked out. A second round of nuclear transfer eliminated both alleles of *GGT1*.

CHO-K1 cells were transfected with cDNA encoding  $\beta$ 1,3GlcNAcT-VI,  $\beta$ 1,3GalT-V,  $\alpha$ 1,2FucT-II and  $\alpha$ 1,3/4FucT-III. Two Le<sup>b</sup> positive clones, 1C5 and 2C2, were studied.

## Isolation and purification of GSLs

The methodological approach to isolate and structurally characterize GSLs is summarized in Figure 4. Experimental details are described in the respective articles and in references cited therein and will not be reiterated in this section.

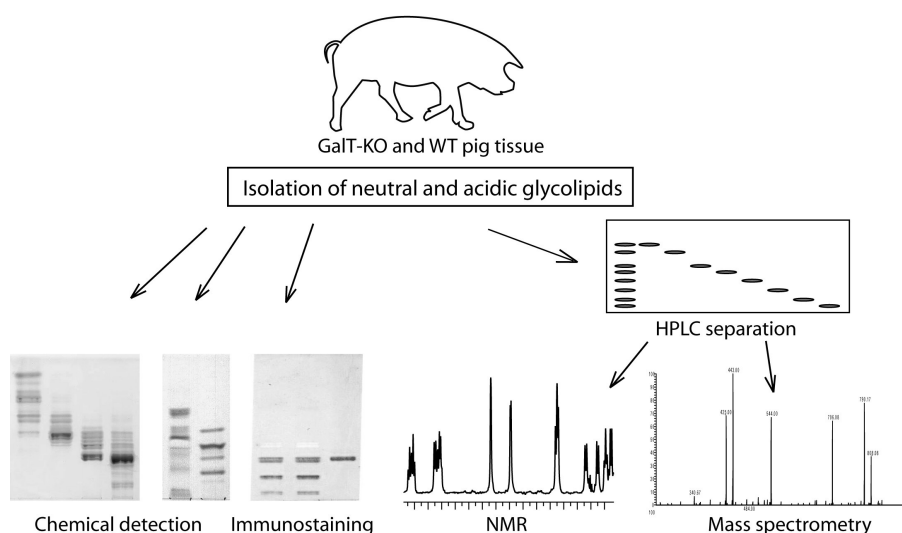

**Figure 4.** *GSLs were isolated from tissues or cells and visualized with chemical reagents, antibodies, lectins and sera. Individual GSL components were purified by HPLC and analyzed by proton NMR spectroscopy and mass spectrometry.*

### *Isolation procedure*

An advantage in studying GSLs is the one-to-one ratio of glycan and ceramide as opposed to glycoproteins where several glycans normally are linked to one peptide sequence which make interpretation complex.

Numerous protocols for isolation of GSLs have been described [140]. In this thesis the method developed by Karlsson was employed [141]. Total lipids extracted from tissue contain a cocktail of phospholipids, sphingomyelin, GSLs and non-lipid contaminants. Mild alkaline methanolysis cleaves labile ester bonds of phospholipids and triglycerides. Some GSLs containing O-acyl groups are alkali labile and may also be lost [141]. GSLs are purified by repeated silicic acid column chromatography of both native and acetylated derivatives. The acetylation procedure shifts the chromatographic properties of neutral GSLs into the nonpolar interval whilst sphingomyelin remains in the polar interval thus enabling separation of these. Ion exchange chromatography separates neutral GSLs from acidic GSLs (sulfatides and gangliosides) and also removes N-acetylated derivatives of alkali stable phospholipids. In this work we separated the neutral GSLs into sub-fractions with approximately 1, 2-3 and  $\geq 3$  sugars (slow-moving fraction) to enrich blood group active GSLs.

Polyglycosylceramides (PGCs, >30 sugars) are not extracted using the above preparation procedure due to their highly polar properties. Miller-Podraza and co-authors developed a method where tissues or cells are peracetylated prior to organic solvent extraction [142]. PGCs have been shown to express a similar repertoire of terminal epitopes as shorter GSLs does [143, 144] and were therefore not included in our studies. PGCs in the membrane may more likely bind to antibodies and lectins, but for our experimental purposes shorter GSLs are more convenient to handle.

When isolating GSLs from limited amounts of biological material, such as the cultured CHO cells in *paper IV*, a condensed protocol with fewer chromatography steps is used in order to minimize loss of material.



### *High Performance Liquid Chromatography*

When sufficient amount of GSLs is available these may be purified by high performance liquid chromatography (HPLC) in order to resolve individual GSL species. The liquid phase gradient is tailored depending on the polarity of the GSLs to be separated. The chromatographic properties of GSLs in a mixture may be so similar that it is not possible to separate them in native form (illustrated in *paper I; figure 2*). Acetylation of the GSLs influences the relative polarity and hence the elution rate on the HPLC column and may therefore be helpful to resolve individual GSL components [145].

### Characterization of GSLs

Structural determination of GSLs in the present thesis means elucidation of type, number and sequence of monosaccharides and anomericity of glycosidic bonds. For this purpose a combination of binding studies, mass spectrometry and proton NMR spectroscopy is preferably used. The structures in the present thesis are in some cases tentative due to limited amounts of material.

### *Thin Layer Chromatography*

High performance thin layer chromatography (HPTLC) can be used to monitor each step of the isolation procedure. HPTLC plates are coated with a superfine layer of silica gel particles and offer an exceptional resolution of individual GSL compounds. The chromatographic separation is mainly determined by the polarity, *i.e.* carbohydrate chain length and to some extent also the degree of hydroxylation and number of hydrocarbons of the ceramide [146]. Neutral GSLs are elegantly resolved using chloroform, methanol and water mixtures, whereas a solvent containing aqueous salts such as KCl or CaCl<sub>2</sub> is preferably used for the separation of gangliosides. A single band on a chromatogram usually contains more than one component wherefore it is helpful to use several different solvent systems.

Chromatographed GSLs can be chemically detected using orcinol or anisaldehyde [141]. Anisaldehyde stains all carbohydrates in characteristic greenish colors, where the shade of green reflects the particular carbohydrate structure. Gangliosides may be detected using the Svennerholm resorcinol-hydrochloride reagent that specifically stains gangliosides in a characteristic purple shade [147]. The resorcinol reagent can also be used to quantify gangliosides in microtiter wells [148].

### *Chromatogram Binding Assay*

Binding of antibodies, lectins, bacteria and viruses directly to chromatographed GSLs using the chromatogram binding assay (CBA) [141, 149] provides information of the glycan chain length as well as the binding epitope [141]. Chemical staining of the GSLs in parallel with immunostaining yields valuable information on the concentration and purity of individual GSL components.

Monoclonal antibodies that appear to be specific in agglutination or immunohistochemical assays often show a high degree of unspecificity when used in CBA. A recent study showed that more than half of 27 antibodies tested by glycan microarray profiling were cross-reactive with other glycans [150]. Therefore, a panel of different antibodies with well-known specificity is useful when assessing GSL reactivity. The temperature and pH dependence should also be evaluated for each antibody as these factors may affect antibody binding and specificity. Structural information should preferably be established in combination with biophysical methods such as mass spectrometry and NMR spectroscopy (see below).

Presentation of GSLs on silicic acid-coated plates does not reflect the actual presentation in biological membranes. The elusive coating of the plates with polyisobutylmethacrylate is believed to “invert” the GSL so that the carbohydrate points away from the silica gel and becomes accessible for binding; however the actual details are not known. The use of model membranes in biosensor-based methods such as surface plasmon resonance (SPR) has revealed that the composition and fluidity of the lipid membrane is a critical parameter in protein-GSL recognition, reviewed in

[151]. SPR has a higher demand for absolutely pure GSLs whereas the chromatography step in CBA enables separation of individual components in a mixture. Loading of GSLs on HPTLC plates results in a high concentration of epitopes in a small area, far from the presentation in lipid rafts.

### *Mass spectrometry*

Gothenburg has a long tradition of mass spectrometry starting with the pioneering work by profs. Stina and Einar Stenhagen [152]. Development of mass spectrometry techniques for GSL analysis revolutionized the field [153]. The first mass spectrum of a GSL was obtained using electron ionization mass spectrometry of trimethylsilylated GlcCer [154]. Subsequently, permethylated [155] and permethylated/reduced [156] derivatives increased the stability and volatility of the molecules.

Today a multitude of techniques for mass spectrometry analysis of native or derivatized GSLs is available. Techniques differ in ionization, separation and detection of the analyzed component. Generally, mass spectrometry provides information on molecular weight, number and type of monosaccharides, sequence and branching of saccharide units and ceramide type.

In *paper III* oligosaccharides were enzymatically released from the ceramide prior to mass spectrometry analysis. The enzyme *Rhodococcus sp* cleaves the linkage between the saccharide and ceramide of acidic and neutral GSLs, producing intact oligosaccharides and free ceramides [157]. The enzyme cannot, however, cleave monoglycosylceramides, glyco glycerolipids or N- or O-glycans. The efficiency with which the enzyme hydrolyzes glycosidic linkages varies depending on GSL series, explaining why the technique is not suitable for quantitative estimations of individual GSLs. Analysis of released oligosaccharides circumvents the complexity of solubilization and ionization of the amphiphatic GSLs, but information on the ceramide is lost. On-line liquid chromatography (LC) separation prior to mass spectrometry analysis adds information of the oligosaccharide *e.g.* regarding the core chain type.

### *Proton NMR spectroscopy*

In the late 1970's Falk *et al.* described a method to analyze permethylated and reduced GSLs dissolved in  $\text{CDCl}_3$  by proton NMR spectroscopy [158-160]. Shortly thereafter Dabrowski *et al.* reported the analysis of native GSLs using DMSO and  $\text{D}_2\text{O}$  [161, 162]. The latter method is less time-consuming and non-destructive, *i.e.* sample can be recovered and used for further experiments.

The NMR spectroscopy phenomenon is based on the fact that atomic nuclei in a strong magnetic field absorb radiation at characteristic frequencies. Interactions between the intrinsic magnetic field of a particular nucleus and the extrinsic, applied, magnetic field determines the chemical shift of each signal. NMR spectroscopy provides information on monosaccharide composition, sequence, conformation and anomericity of glycosidic bonds. Information is also obtained regarding ceramide composition, *e.g.* on the degree of hydroxylation and presence of double bonds. NMR spectroscopy from a glycoconjugate perspective is described in detail in [163].

The number of spin systems, *i.e.* the different sugar residues, can be revealed by 1D NMR. For resolving the connectivity of the individual spin systems 2D NMR is useful. Numerous 2D NMR techniques are available including correlated spectroscopy (COSY) and nuclear overhauser effect spectroscopy (NOSEY). In this thesis we have used a combination of 1D and COSY NMR experiments (*papers I-III*).

Establishment of the oligosaccharide is mainly derived from the anomeric region of the spectrum (4.1-5.4 ppm), where the anomeric proton (H-1) of each monosaccharide gives rise to a signal at a specific chemical shift (Figure 5). The chemical shift gives information on *e.g.* type of monosaccharide and glycosidic linkage. Supplementary information from the other ring protons, whose shifts and spatial arrangements often may be deduced from 2D  $^1\text{H}$ - $^1\text{H}$  NMR experiments such as COSY and NOESY, are frequently required. Integration of the H-1 signals establishes the number of monosaccharides in the sequence. The anomeric signal is in the form of a doublet due to coupling with the H-2 proton, where the anomericity ( $\alpha$  or  $\beta$  linkage to the next

sugar) can be deduced from the splitting (J-coupling) of the signal.  $\alpha$ -anomers have a smaller  $J_{1,2}$  coupling constant (1-4 Hz) than  $\beta$ -anomers (6-10 Hz). H-5 proton resonances, *e.g.* from fucose and other ring protons may shift into the anomeric region, whereas resonances from ring protons and methyl groups from hexosamine and fucose are found upfield of the anomeric region. Resonance regions are outlined in Figure 5. The elucidation of spectra is greatly facilitated by comparison with reference spectra of well-known structures. Since GSLs in a DMSO/D<sub>2</sub>O mixture form temperature-dependent micelles, reference spectra must be recorded under the same conditions in to allow comparative interpretation [164].

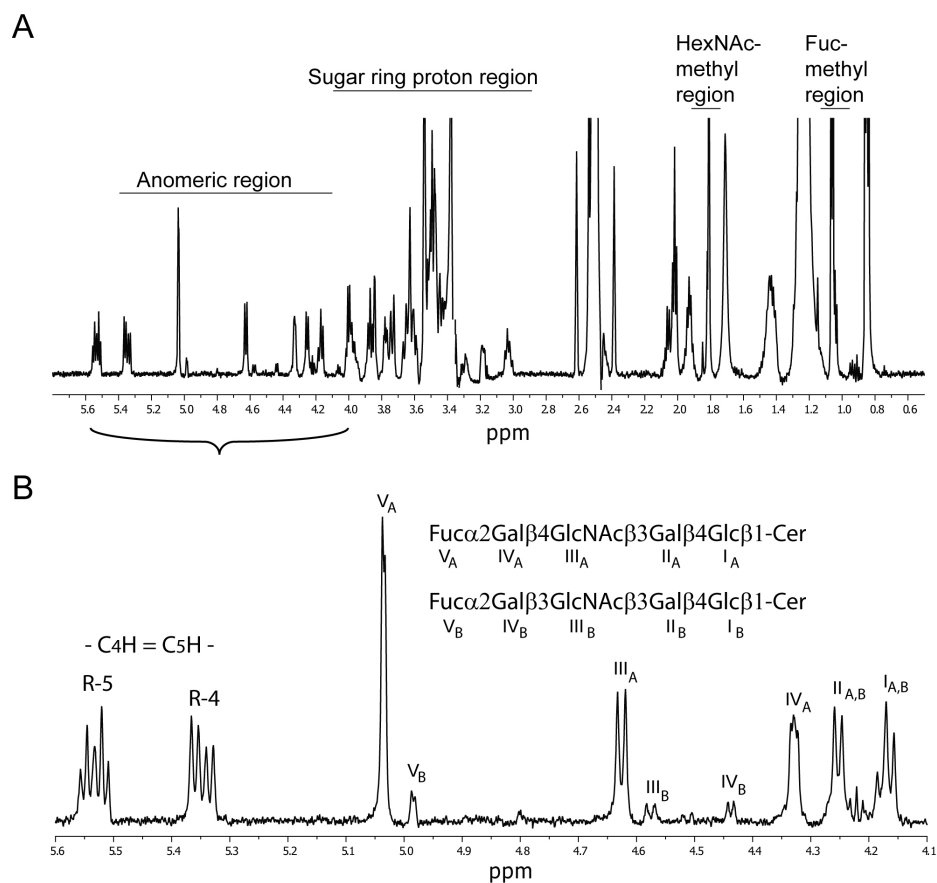

**Figure 5.** A) Full 1D proton NMR spectrum of H5 type 2 (90%) and H5 type 1 (10%). B) Anomeric resonances of H5 type 2 (A) and H5 type 1 (B) denoted with roman numerals I-V. Note the difference in  $J_{1,2}$  of  $\alpha$ -anomers and  $\beta$ -anomers. R-4 and R-5 refer to the -C4H=C5H- protons of the sphingosine base.

# RESULTS AND DISCUSSION

The four papers presented in this thesis all focus on carbohydrate expression from a GSL perspective in relation to a defined change in glycosyltransferase gene setup. In this section results are briefly summarized and discussed whereas details of interpretation are given in the respective articles.

## $\alpha$ 1,3GalT-KO effects

*Papers I-III* investigate if  $\alpha$ 1,3GalT-KO pig expresses residual Gal $\alpha$ 3 antigens and whether the genetic modification also results in other alterations of the GSL pattern. As discussed throughout the thesis the GSL pattern differs markedly between different strains, individuals and organs. We have therefore examined small intestine, pancreas, kidney and heart. Pigs have a blood group AO system [165], comparable to the human ABO system, and in this work we investigated organs of both blood groups.

### *Lack of Gal $\alpha$ 3 GSL antigens*

When our project was initiated the first data from clinical trials using  $\alpha$ 1,3GalT-KO pig donors had recently been obtained [120, 121, 166]. Results showed some prolongation of survival of these organs in nonhuman primates, but were not the success aimed for. An early study reported that  $\alpha$ 1,3GalT-KO mice and pig fetal fibroblasts still expressed low levels of the Gal $\alpha$ 3 antigen [167, 168]. It was therefore proposed that residual Gal $\alpha$ 3 antigens remained also in  $\alpha$ 1,3GalT-KO pigs thereby compromising graft survival.

### Immunostaining

Immunostaining of WT organs identified Gal $\alpha$ 3-positive neutral fractions migrating in the 5, 7/9 and >12 sugars region (small intestine and pancreas), 5 and 7/9 sugar regions (heart) and 5, 6, 7/9 and >12 sugar regions (kidney), in accordance with previous studies [96, 169, 170]. This is illustrated for the heart and kidney GSLs in Figure 6. The figure also shows the complete absence of Gal $\alpha$ 3 determinants in  $\alpha$ 1,3GalT-KO tissues.

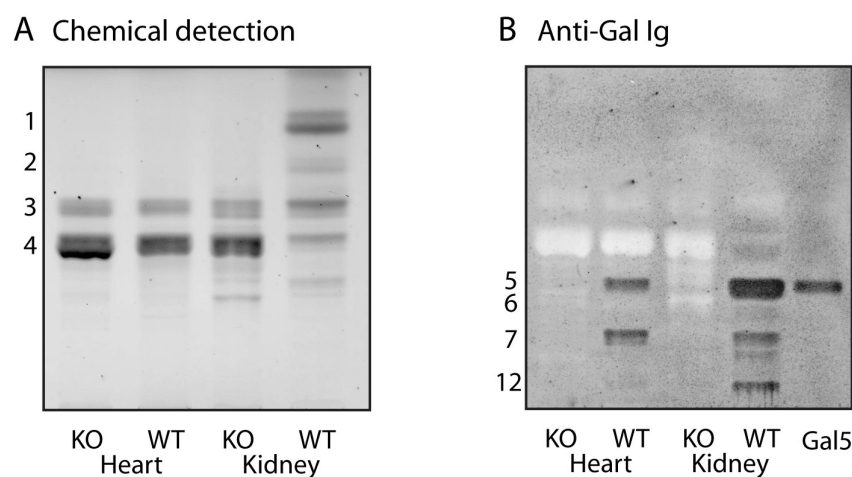

**Figure 6.**  $\alpha$ 1,3GalT-KO and WT pig heart and kidney GSLs chemically detected with anisaldehyde (A) and immunostained with human affinity-purified anti-Gal Ig (B).  $\alpha$ 3Gal-positive bands were detected in the 5 and 7 sugar regions of WT heart and in the 5, 6, 7/9 and >12 sugar regions of WT kidney. Purified Gal $\alpha$ 3nLc4 (Gal5) was used as a reference. Numbers to the left denote number of sugars in the glycan chain.

One Gal $\alpha$ 3-positive compound only was seen amongst acidic GSLs. This compound was detected in the WT kidney and probably corresponded to the VI<sup>3</sup>NeuAcVI<sup>3</sup> $\alpha$ Gal-iso-nLc8Cer or VI<sup>3</sup>NeuAcVI<sup>3</sup> $\alpha$ GalV<sup>3</sup> $\alpha$ Fuc-iso-nLc8Cer previously reported by Bouhours and co-authors [171].

### Structural determination by mass spectrometry and proton NMR spectroscopy

In order to confirm the absence of Gal $\alpha$ 3 antigens in KO tissues and to establish their structures in WT tissues we analyzed GSLs by means of mass spectrometry and proton NMR spectroscopy. In *paper III*, LC-ESI/MS was used for rapid and sensitive screening of the heart and kidney GSLs. Determination of GSLs from these organs are

of utmost importance since heart and kidney have been evaluated in preclinical  $\alpha$ 1,3GalT-KO pig-to-baboon transplantation trials [120-122, 124]. In WT tissues we showed that the pentaglycosylceramide detected by immunostaining (Figure 6) corresponds to the Gal $\alpha$ 3nLc4 compound described in several studies before [96, 169, 170, 172]. We also identified a hexasaccharide in kidney, most probably corresponding to Gal $\alpha$ 3Le<sup>x</sup> [95] and a heptasaccharide in kidney and heart most probably corresponding to Gal $\alpha$ 3nLc6 [173].

LC-ESI/MS did not detect oligosaccharides exceeding 8 sugars in length, although immunostaining revealed that Gal $\alpha$ 3 antigens with >12 sugars were present in WT kidney. This may be due to irreversible binding of long-chain saccharides to the LC column or due to inability of the enzyme to cleave these structures.

In *papers I and II* we analyzed small intestine and pancreas. When these experiments were performed we did not have access to mass spectrometry, but the amount of WT and  $\alpha$ 1,3GalT-KO small intestinal GSLs allowed HPLC purification and subsequent analysis using proton NMR spectroscopy. Similarly to kidney and heart the Gal $\alpha$ 3-positive pentasaccharide in small intestine corresponded to Gal $\alpha$ 3nLc4 [169, 170].

Small intestine from pig and other mammals has previously been shown to contain large amounts of long-chain blood group active GSLs [174-178]. The intricacy of small intestinal GSLs is also reflected by their specific anatomic localization [57, 58, 179]. When we analyzed GSLs in the 7/9 sugar region a complex mixture of branched compounds carrying blood group H and  $\alpha$ 3Gal determinants was revealed.

Two different Gal $\alpha$ 3-antigens were identified (*paper II*). One of these was a linear nona- or heptaglycosylceramide with a Gal $\alpha$ 3Gal $\beta$ 4GlcNAc $\beta$ 3 trisaccharide linked to nLc6 or nLc4. From an NMR point of view it was not possible to establish the number of lactosamine disaccharide units, but since it co-eluted in the same HPLC fraction as 9 and 10 sugar structures it was believed to be a nonaglycosylceramide. However the



detection of Gal $\alpha$ 3nLc6 in the kidney and heart (*paper III*) argues in favor of the heptaglycosylceramide annotation. The second Gal $\alpha$ 3 antigen in the 7/9 sugar region was a branched decaglycosylceramide with Gal $\alpha$ 3Gal $\beta$ 4GlcNAc $\beta$ 3/6 branches on a type 2 tetrasaccharide core [180], shown in Figure 7A.

Analysis of the GSLs migrating in the >12 sugar region revealed a complex mixture of at least three different overlapping triantennary pentadecaglycosylceramides in WT and  $\alpha$ 1,3GalT-KO tissues with the general structure X-Gal $\beta$ 3/4GlcNAc $\beta$ 3(Y-Gal $\beta$ 3/4GlcNAc $\beta$ 6)Gal $\beta$ 4GlcNAc $\beta$ 3(Z-Gal $\beta$ 3/4GlcNAc $\beta$ 6)-nLc4 [181]. X, Y and Z were shown to be Fuc $\alpha$ 2, Gal $\alpha$ 3 or Gal $\alpha$ 4 (Figure 7B). The decaglycosylceramide and the pentadecaglycosylceramide have previously been isolated from rabbit erythrocytes [180, 181], but to our knowledge, this is the first time they are reported in pig tissues.

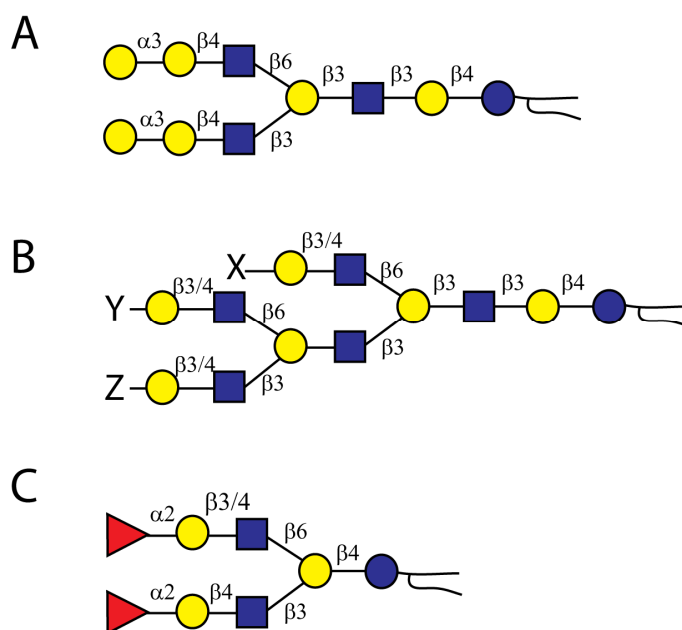

**Figure 7.** A) decaglycosylceramide identified in WT small intestine. B) pentadecaglycosylceramide identified in  $\alpha$ 1,3GalT-KO and WT small intestine. X, Y and Z correspond to Fuc $\alpha$ 2, Gal $\alpha$ 3 or Gal $\alpha$ 4. The Gal $\alpha$ 3 epitope was not detected in the  $\alpha$ 1,3GalT-KO tissue. C) two novel octaglycosylceramides with a type 1 or type 2 branch from  $\alpha$ 1,3GalT-KO pig small intestine. Compounds A) and B) have previously been reported in rabbit erythrocytes with X,Y and Z as Gal $\alpha$ 3 [180, 181].

It should be emphasized that Gal $\alpha$ 3 antigens were not detected in any of the  $\alpha$ 1,3GalT-KO pig fractions, in agreement with preclinical pig-to-nonprimate trials where HAR was completely overcome.

### *Production of compensatory GSLs*

Our hypothesis was that the metabolic block of the  $\alpha$ 1,3GalT would lead to i) accumulation of the immediate LacNAc precursor, ii) formation of repetitive LacNAc units or iii) that the biosynthesis would be driven towards competing pathways. These alternatives are briefly outlined below.

### *Precursor accumulation*

Normally  $\alpha$ 1,3GalT converts the LacNAc precursor. In the absence of compensatory glycosyltransferases LacNAc units of varying lengths may accumulate.  $\alpha$ 1,3GalT-KO and WT heart and kidney all expressed the uncapped precursor nLc4 compound. Although the LC-ESI/MS technique used here has limitations regarding quantification of individual components, it can be used for interrelational estimations. The amount of nLc4 in GalT-KO heart and kidney was 4 times the level of nLc4 in corresponding WT tissues. Also, the extended LacNAc compounds nLc6 and nLc8 were tentatively established in  $\alpha$ 1,3GalT-KO pig kidney and heart. WT heart did not express any nLc6 or nLc8 and WT kidney did only express nLc6. LacNAc is the precursor substance in the blood group Ii system, and is abundantly expressed in human cells and tissues. Nevertheless, autoantibodies called cold agglutinins directed towards LacNAc are produced [182] and it is unclear whether this is of significance in xenorejection.

### *Competing pathways*

Similar to Gal $\alpha$ 3-determinants, blood group H type 2 compounds are synthesized from the LacNAc precursor, hence  $\alpha$ 1,2FucT is a biosynthetic competitor of  $\alpha$ 1,3GalT. Increased levels of long chain H type 2 compounds in  $\alpha$ 1,3GalT-KO pancreas, heart and kidney compared to the corresponding WT tissues were detected using immunostaining (*papers I and III*).

Proton NMR spectroscopy identified two novel blood group H structure in  $\alpha 1,3\text{GalT-KO}$  small intestine (Figure 7C). These were unusual in that the six-linked blood group H trisaccharide branch (type 1 and 2 core chains, respectively) was attached directly to a lactosyl core instead of a tetrasaccharide core (*Paper II*) [162]. The tetrasaccharide core-based structures were also identified. The novel lactosyl core based structures were not detected in the corresponding WT tissue. The synthesis cannot be explained by a direct effect of the genetic modification; however it may be a general consequence of the disturbed glycosyltransferase balance.

Interestingly, the  $x_2$  antigen ( $\text{GalNAc}\beta 3\text{nLc4}$ ) was identified in kidney and heart of the  $\alpha 1,3\text{GalT-KO}$  pig (*paper III*). WT kidney expressed trace amounts of the  $x_2$  antigen whereas WT heart was completely negative.  $x_2$  is most commonly found on human erythrocytes and has to our knowledge not been reported in pig before [183].

Furthermore, the P1 antigen ( $\text{Gal}\alpha 4\text{nLc4}$ ) was identified in the  $\alpha 1,3\text{GalT-KO}$  kidney but was absent in WT kidney and in heart tissues. The transferases responsible for  $x_2$  and P1 synthesis ( $\beta 1,3\text{GalNAcT}$  and  $\alpha 1,4\text{GalT}$ ) both use nLc4 as substrate and hence compete with  $\alpha 1,3\text{GalT}$  (Figure 8). Interestingly, accumulation of nLc4 [80] as well as the  $x_2$  antigen [184] have been reported in erythrocytes from individuals of the rare human blood group p phenotype, which lack the  $P^k$  transferase responsible for the synthesis of Gb3, an intriguing concurrence to the precursor competition in the  $\alpha 1,3\text{GalT-KO}$  pig observed in the present work.

$\alpha 2,3\text{SiaT}$  and  $\alpha 1,3\text{GalT}$  have been shown to compete for the same acceptor in transfected CHO cells [129]. Surprisingly, the level of gangliosides appeared to be decreased to about half the WT level in the  $\alpha 1,3\text{GalT-KO}$  small intestine and pancreas (Figure 8), reported in *paper I*. If the decrease in gangliosides in these tissues is a characteristic of the  $\alpha 1,3\text{GalT-KO}$ , or due to an inter-individual variation between the pigs can only be speculated upon. NeuGc type gangliosides are regarded as non-Gal antigens and are found in large amounts in pig tissues [185, 186]. The NeuGc epitope is expressed in most mammals, but is absent from cells and tissues of humans due to

an inactivation of the hydroxylase catalyzing the conversion of CMP-NeuAc to CMP-NeuGc, explaining why we produce antibodies directed towards NeuGc [187]. The role of NeuGc in xenotransplantation is unclear; however the opinion in the xenotransplantation field is that it may be the next target for genetic modification.

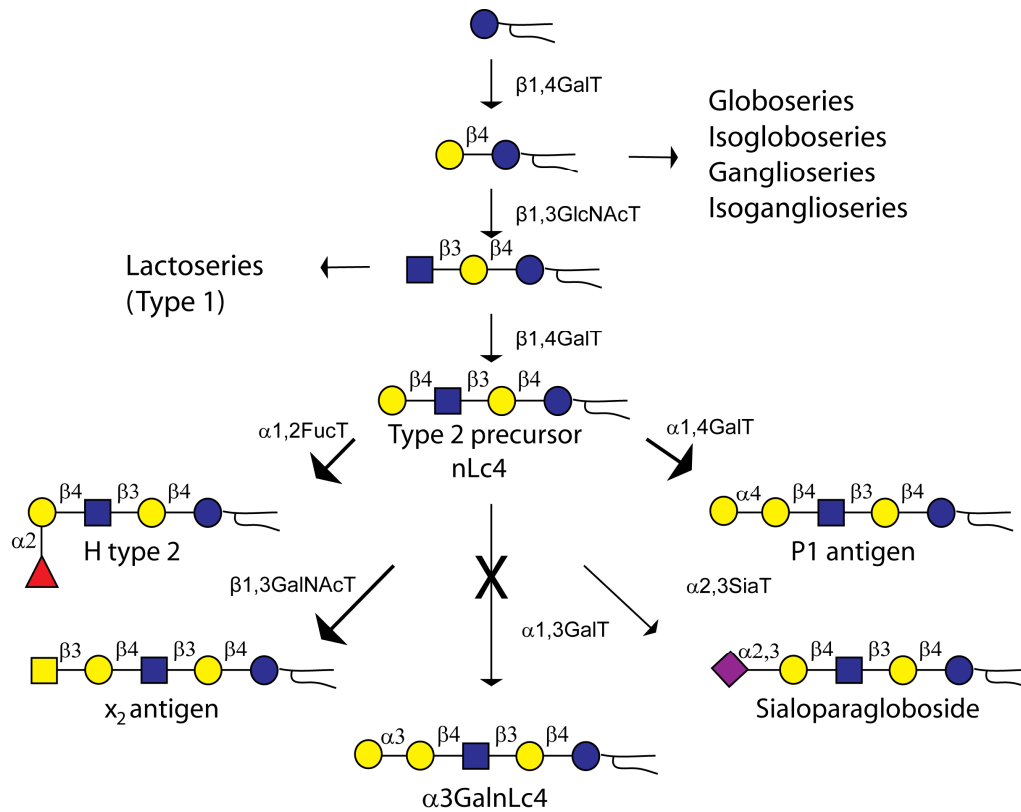

**Figure 8.** Schematic presentation of the synthesis of Gal $\alpha$ 3nLc4 antigen and competing biosynthetic pathways. Arrows in bold denote synthesis pathways that were upregulated in the present work.

### *Other non-Gal GSL candidates*

A second enzyme, termed iGb3 synthase is capable of producing the Gal $\alpha$ 3 linkage and has been suggested to play a role in xenorejection. iGb3 synthase is GSL specific and elongates primarily LacCer but can also act on GalCer and Gb3 [188]. iGb3 is described in various mammals [57, 189-191] occasionally elongated into iGb4 and iGb5. In *paper I* we did not detect iGb3 in  $\alpha$ 1,3GalT-KO or WT small intestine. However, amongst the tetraglycosylceramides trace amounts of the fucosylated form fucosyl $\alpha$ 2-iGb3 (Fuc-iGb3), were detected, previously reported in hog stomach mucosa [192]. Neither iGb3 nor Fuc-iGb3 was found in heart and kidney (*paper III*). Fuc-iGb3 is not believed to have any adverse effects in xenotransplantation.

Like iGb3, the Forssman pentasaccharide has only been described in the form of GSL. Forssman is expressed in a tissue-specific and developmentally regulated manner in various mammals [193-196]. Hakomori reported that about 90% of the human population produce antibodies directed against the Forssman antigen [197], explaining why Forssman is regarded a xenoepitope. Nevertheless the Forssman antigen has been found in human tumors and also in small amounts in normal kidney [198]. Forssman GSL has not been detected in pig previously, nor did we detect it in our studies (*papers I and III*). The involvement of Forssman in rejection of xenoorgans is unlikely.

### **Reactivity with human and baboon serum antibodies**

In *paper III* baboon serum samples obtained before and at various time intervals after  $\alpha$ 1,3GalT-KO pig-to-baboon cardiac grafting [199] were available for our studies. Sera were screened against neutral and acidic heart and kidney GSLs and compared to the binding pattern of human serum. The aim was to identify potential pre-formed and elicited antibodies with antigenic reactivity towards pig GSLs. Human and baboon serum antibodies reacted strongly with Gal $\alpha$ 3 epitopes in WT organs. The staining reaction was more intense using human serum, indicating a higher prevalence of anti-

Gal antibodies in the human population than in the baboon population. A neutral pentasaccharide was stained in all fractions, most pronounced in the  $\alpha$ 1,3GalT-KO kidney. As was revealed by structural determination pentasaccharides in this tissue consisted of H5 types 1 and 2, Gb5, FucGg4, Le<sup>x</sup>-5, P1 and x<sub>2</sub> antigens (Table 1 and 2, paper III). None of these have any reported antigenic activity against human antibodies.

Reactivity towards NeuGc antigens in acidic GSLs was detected with human serum, but not baboon serum as they, contrary to humans, express the NeuGc antigen. Baboon serum antibodies, on the other hand, reacted with several acidic  $\alpha$ 1,3GalT-KO compounds that were lacking or present in lower amounts in the corresponding WT fractions (Figure 5, paper III). These compounds were present in very small amount, and have therefore not yet been structurally determined. The difference in reactivity pattern of baboon and human serum antibodies indicate the limitations of non-human primates as preclinical human models.

The inhibition of HAR is the main accomplishment with the  $\alpha$ 1,3GalT-KO pig from a clinical point of view. The pig is considered an appropriate genetic background for additional modifications, such as incorporation of human complement regulators. The hope is that the inhibition of HAR and AVR will lead to accommodation, *i.e* the long term graft survival despite circulating xenoreactive antibodies [200].

## Glycosyltransferase core chain dependence

In Paper IV the lipid/protein core dependence of Lewis antigen producing glycosyltransferases was compared. We aimed to engineer cells that produce Le<sup>b</sup> and support adhesion of BabA-positive *H. pylori*, and thus may be used as an *in vitro* model for detailed host/microbe binding studies. Glycosyltransferases were selected primarily to mediate Le<sup>b</sup> expression on core 3 O-glycans since this is the most likely configuration of the natural Le<sup>b</sup> receptor in stomach mucosa and also because glycan expression on O-glycans in mucin domains is expected to yield a higher density of the

epitope than expression on N-glycans or GSLs [201]. From a glycobiological perspective we aimed to compare the Le<sup>b</sup> expression on GSLs, N- and O-glycans, and observe the expression of Le<sup>a</sup>, Le<sup>x</sup> and Le<sup>y</sup>, produced via competing biosynthesis pathways.

### *Lewis antigen production differs on GSL and protein cores*

The glycosyltransferases examined had clearly different specificity for different core chains (Figure 9). Interestingly  $\alpha$ 1,3/4FucT-III was shown to act on the type 1 precursor to produce the Le<sup>a</sup> epitope on N- and O-glycans but not on a GSL backbone. On the other hand, the enzyme acted on the H type 1 precursor to produce Le<sup>b</sup> epitopes on all backbones and on H type 2 to produce Le<sup>y</sup> on GSLs and N-glycans. Possible explanations for this may be separate biosynthesis pathways of GSLs and proteins in the ER/Golgi pathway, or substrate-dependent competition between  $\alpha$ 1,3/4FucT-III and  $\alpha$ 1,2FucT-II. It has been reported that  $\alpha$ 1,3FucT-IV selectively acts on GSLs whilst  $\alpha$ 1,3FucT-VII preferentially acts on glycoproteins [202], but besides this limited studies have been performed comparing glycosyltransferase substrate specificity for different core structures.

The observation of Le<sup>x</sup> GSL in both transfected clones and parental cells was surprising. Parental CHO cells have been reported to lack  $\alpha$ 1,3FucT activity, thus being unable to add fucose in  $\alpha$ 3-linkage [203]. However the CHO cell genome contains at least two silent  $\alpha$ 1,3FucT genes that can be activated upon *e.g.* mutagenesis or transfection [127]. Some of the most well known examples are the LEC11 and LEC12 mutants which both express Le<sup>x</sup>, sialyl Le<sup>x</sup> and VIM-2 determinants due to an activating event of  $\alpha$ 1,3FucT-VI and  $\alpha$ 1,3FucT-IX, respectively [204]. The Le<sup>x</sup> activity was observed in the >12 sugar region and is, to our knowledge, the most complex GSL detected in CHO cells. Le<sup>x</sup> activity was not observed on glycoproteins. This may explain why it has previously not been reported since limited attention has been paid to CHO cell GSLs compared to glycoproteins. Unfortunately the limited amount of GSL material did not permit further structural studies by mass spectrometry or proton NMR spectroscopy.

### Binding to *H. pylori*

Both clones examined supported adhesion of BabA-positive *H. pylori*, and may therefore serve as an *in vitro* model for molecular and cell biological studies on host/microbe relationship. Also, since Lewis antigen expression differed between GSLs, N- and O-glycans, the two Le<sup>b</sup> expressing clones may be useful in studies to dissect the role of carrier glycans for *H. pylori* binding.

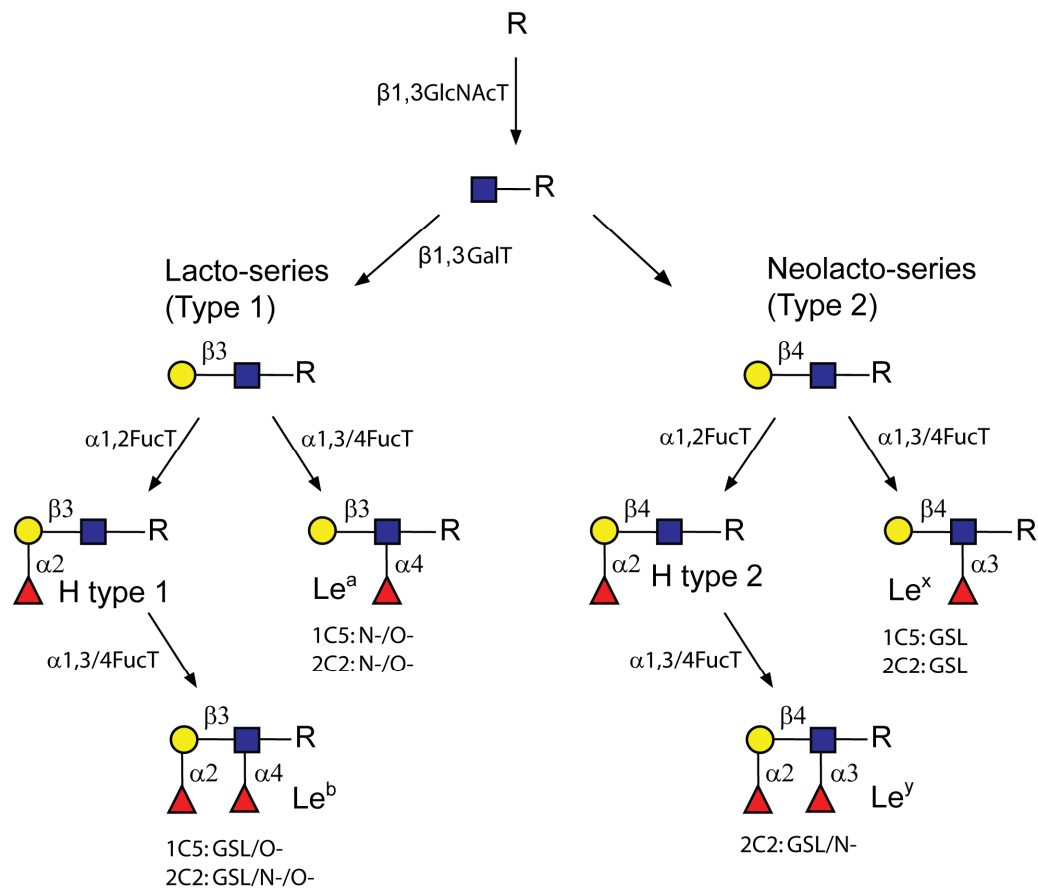

**Figure 9.** Schematic presentation of Lewis antigen biosynthesis. Transfected glycosyltransferase are denoted above the arrows. The occurrence of each epitope on GSLs, N- and O-glycans in clones 1C5 and 2C2 is denoted below the glycan symbols.



## SUMMARY AND FUTURE PERSPECTIVES

Lack of Gal $\alpha$ 3 determinants in  $\alpha$ 1,3GalT-KO tissues is a direct effect of the genetic modification, whereas the changed levels of blood group H compounds, sialylated structures and the P1 and x<sub>2</sub> antigens rather are secondary effects due to the altered glycosyltransferase repertoire (*papers I-III*). Limited data is available regarding localization of, and competition between, specific glycosyltransferases. However,  $\alpha$ 1,2FucT is localized in the *medial* Golgi [205] and  $\alpha$ 1,3GalT in the *trans* Golgi [129, 206]. The growing oligosaccharide chain will therefore first encounter  $\alpha$ 1,2FucT and become inaccessible to subsequent  $\alpha$ 3-galactosylation. Consequently, knockout of  $\alpha$ 1,3GalT should not affect the level of fucosylation. Since blood group H compounds were increased, it supports the current belief that glycosyltransferases localize in overlapping gradients in the ER/Golgi pathway which makes it impossible to predict the effect of glycosyltransferase modifications on the glycolandscape.

The lack of terminal Gal $\alpha$ 3 epitopes and upregulation of the x<sub>2</sub> and P1 antigens makes it tempting to propose that  $\alpha$ 1,3GalT-KO pig tissues have adopted a “humanized” glycosylation pattern. However, *de novo* synthesis of foreign GSLs due to a knockout modification is unlikely. It is more likely that pigs normally synthesize minute amounts of these antigens which are increased upon  $\alpha$ 1,3GalT elimination.

GSLs and glycoproteins share many similarities in terminal carbohydrate sequences whereas the core structures linked to the protein or lipid carriers differ. Therefore the terminal carbohydrate determinants may be synthesized by common glycosyltransferases [14]. Few studies comparing lipid and protein bound blood group expression in cells or tissues have been reported. Expression of terminal Lewis epitopes in glycosyltransferase modified CHO cells differed quantitatively and qualitatively in the same cell clones depending on whether the glycan was protein or lipid core based (*paper IV*). Consequently it would be highly interesting to analyze

protein bound glycans from  $\alpha$ 1,3GalT-KO pig in order to obtain a more complete view of the cell membrane carbohydrate expression.

Small intestine is a rich source of complex blood group active GSLs, especially fucolipids. The abundance of GSLs and their subcellular distribution in epithelial cells renders small intestine an interesting and relevant tissue for detailed studies of glycosyltransferase activity on different core chain types. Interestingly, it has been shown that the majority of the small intestinal blood group active glycoproteins is of type 2 origin whereas the major GSL counterparts have type 1 core chains [207]. We have initiated a study where we compare small intestinal GSL from WT,  $\alpha$ 1,3GalT-KO and a combined  $\alpha$ 1,3GalT-KO/ $\alpha$ 1,2FucT transgenic pig with the aim to further explore the relation between cell membrane phenotype and cellular glycosyltransferases.

As discussed throughout this thesis, many pathophysiological conditions such as cancer, inflammation and infection are associated with aberrant glycosylation. A deeper comprehension of the correlation between expression of lipid and protein-linked cell membrane carbohydrates and the activities of related glycosyltransferases may prove valuable in diagnosis and development of potential therapies.

# ACKNOWLEDGEMENTS

Det finns många personer jag är ytterst tacksam mot för hjälp och uppmuntran under de här åren. Några av dessa är:

Min handledare Michael Breimer – för att du antog mig som doktorand och för din generositet och imponerande förmåga att finna konstruktiva lösningar på alla problem som kan uppstå!

Mina bihandledare – Bo Samuelsson, tack för att du delar med dig av dina kunskaper och alltid är entusiastisk inför nya fynd. Susann Teneberg, för att du alltid ställer upp med hjälp och goda råd vad det än gäller.

Mina medförfattare – Jonas Ångström för din unika kompetens inom NMR och lika imponerande tålamod inför min aldrig sinande ström av frågor. Lennart Rydberg, för svar på alla mina antikroppsfrågor. Hasse Karlsson, för MS-hjälp och insyn i hur man packar den ultimata kolonnen. Jan Holgersson, Jonas Löfling, Thomas Borén och Sara Eriksson för gott samarbete på CHO-cellartikeln. My sincere gratitude to Henk-Jan Schuurman, Frank Dor, David Ayares and Carol Phelps for great collaboration.

Karl-Anders Karlsson – för att du har tagit dig tid att ge mig råd och synpunkter som i mer än ett fall visat sig vara absolut avgörande. Jan-Eric Månsson, tack för många givande diskussioner om glykosfingolipider och hur dessa angrips på bästa sätt. I am deeply grateful to Jasna Peter-Katalinic and Laura Bindila for sharing your unique competence in, and true passion for, mass spectrometry.

Nya och gamla medlemmar i GTB-gruppen – Lola, för alla våra fantastiska diskussioner om stort och smått, forskning och annat och för att du är den bästa rumskompis någon kan önska sig! Luis, thank you for your patience and friendship when introducing me to the glyco- and worm-world; the lab was empty when you left! Ulla och Christel för all hjälp och trevligt fikasällskap genom åren. Tack Anki, Angela och John.

Nya och gamla medlemmar i glykobiologi-gruppen – Göran, Ammi, Giti, Eva, Gustaf, Jonas, Adnan, Johanna, Camilla och Inger för fantastiskt trevliga luncher, resor och forskningsdiskussioner jag inte klarat mig utan!

Alla vänner på Sahlgrenska, Medicinareberget och inom GLIBS. Ett särskilt tack till Nina för trevligt resesällskap, oräkneliga glykodiskussioner och inte minst för lånet av katterna som hållit mig sällskap under många sena kvällar vid datorn.

Mina underbara vänner – det ska bli så roligt att hinna umgås med er igen!  
Världens bästa familj – för allt stöd man någonsin kan få, alltid!  
Peter – för ALLT!

## REFERENCES

1. Singer, S.J. and G.L. Nicolson, *The fluid mosaic model of the structure of cell membranes*. Science, 1972. **175**(23): p. 720-31.
2. Simons, K. and G. van Meer, *Lipid sorting in epithelial cells*. Biochemistry, 1988. **27**(17): p. 6197-202.
3. Simons, K. and E. Ikonen, *Functional rafts in cell membranes*. Nature, 1997. **387**(6633): p. 569-72.
4. Kjellen, L. and U. Lindahl, *Proteoglycans: structures and interactions*. Annu Rev Biochem, 1991. **60**: p. 443-75.
5. Kornfeld, R. and S. Kornfeld, *Assembly of asparagine-linked oligosaccharides*. Annu Rev Biochem, 1985. **54**: p. 631-64.
6. Jentoft, N., *Why are proteins O-glycosylated?* Trends Biochem Sci, 1990. **15**(8): p. 291-4.
7. Collins, B.E. and J.C. Paulson, *Cell surface biology mediated by low affinity multivalent protein-glycan interactions*. Curr Opin Chem Biol, 2004. **8**(6): p. 617-25.
8. Cummings, R.D., *Structure and function of the selectin ligand PSGL-1*. Braz J Med Biol Res, 1999. **32**(5): p. 519-28.
9. Moloney, D.J., et al., *Fringe is a glycosyltransferase that modifies Notch*. Nature, 2000. **406**(6794): p. 369-75.
10. Karlsson, K.A., *Meaning and therapeutic potential of microbial recognition of host glycoconjugates*. Mol Microbiol, 1998. **29**(1): p. 1-11.
11. Jacewicz, M., et al., *Pathogenesis of shigella diarrhea. XI. Isolation of a shigella toxin-binding glycolipid from rabbit jejunum and HeLa cells and its identification as globotriaosylceramide*. J Exp Med, 1986. **163**(6): p. 1391-404.
12. King, C.A. and W.E. van Heyningen, *Evidence for the complex nature of the ganglioside receptor for cholera toxin*. J Infect Dis, 1975. **131**(6): p. 643-8.
13. Leffler, H., et al., *Chemical and clinical studies on the interaction of Escherichia coli with host glycolipid receptors in urinary tract infection*. Scand J Infect Dis Suppl, 1982. **33**: p. 46-51.
14. Rauvala, H. and J. Finne, *Structural similarity of the terminal carbohydrate sequences of glycoproteins and glycolipids*. FEBS Lett, 1979. **97**(1): p. 1-8.
15. Sprong, H., et al., *UDP-galactose:ceramide galactosyltransferase is a class I integral membrane protein of the endoplasmic reticulum*. J Biol Chem, 1998. **273**(40): p. 25880-8.
16. Joziassse, D.H., *Mammalian glycosyltransferases: genomic organization and protein structure*. Glycobiology, 1992. **2**(4): p. 271-7.
17. Toivonen, S., O. Aitio, and O. Renkonen, *alpha 2,3-Sialylation of terminal GalNAc beta 1-3Gal determinants by ST3Gal II reveals the multifunctionality of the enzyme. The resulting Neu5Ac alpha 2-3GalNAc linkage is resistant to sialidases from Newcastle disease virus and Streptococcus pneumoniae*. J Biol Chem, 2001. **276**(40): p. 37141-8.
18. Breton, C., J. Mucha, and C. Jeanneau, *Structural and functional features of glycosyltransferases*. Biochimie, 2001. **83**(8): p. 713-8.
19. de Graffenried, C.L. and C.R. Bertozzi, *The roles of enzyme localisation and complex formation in glycan assembly within the Golgi apparatus*. Curr Opin Cell Biol, 2004. **16**(4): p. 356-63.

20. Schachter, H., *The 'yellow brick road' to branched complex N-glycans*. *Glycobiology*, 1991. **1**(5): p. 453-61.
21. Esko, J.D., *Genetic analysis of proteoglycan structure, function and metabolism*. *Curr Opin Cell Biol*, 1991. **3**(5): p. 805-16.
22. Stanley, P. and E. Ioffe, *Glycosyltransferase mutants: key to new insights in glycobiology*. *Faseb J*, 1995. **9**(14): p. 1436-44.
23. Colley, K.J., *Golgi localization of glycosyltransferases: more questions than answers*. *Glycobiology*, 1997. **7**(1): p. 1-13.
24. Gleeson, P.A., *Targeting of proteins to the Golgi apparatus*. *Histochem Cell Biol*, 1998. **109**(5-6): p. 517-32.
25. Munro, S., *Localization of proteins to the Golgi apparatus*. *Trends Cell Biol*, 1998. **8**(1): p. 11-5.
26. Opat, A.S., C. van Vliet, and P.A. Gleeson, *Trafficking and localisation of resident Golgi glycosylation enzymes*. *Biochimie*, 2001. **83**(8): p. 763-73.
27. Bretscher, M.S. and S. Munro, *Cholesterol and the Golgi apparatus*. *Science*, 1993. **261**(5126): p. 1280-1.
28. Orci, L., et al., *Heterogeneous distribution of filipin--cholesterol complexes across the cisternae of the Golgi apparatus*. *Proc Natl Acad Sci U S A*, 1981. **78**(1): p. 293-7.
29. Sasai, K., et al., *The critical role of the stem region as a functional domain responsible for the oligomerization and Golgi localization of N-acetylglucosaminyltransferase V. The involvement of a domain homophilic interaction*. *J Biol Chem*, 2001. **276**(1): p. 759-65.
30. Nilsson, T., et al., *Kin recognition. A model for the retention of Golgi enzymes*. *FEBS Lett*, 1993. **330**(1): p. 1-4.
31. Nilsson, T., et al., *Kin recognition between medial Golgi enzymes in HeLa cells*. *Embo J*, 1994. **13**(3): p. 562-74.
32. Opat, A.S., F. Houghton, and P.A. Gleeson, *Medial Golgi but not late Golgi glycosyltransferases exist as high molecular weight complexes. Role of luminal domain in complex formation and localization*. *J Biol Chem*, 2000. **275**(16): p. 11836-45.
33. Munro, S., *An investigation of the role of transmembrane domains in Golgi protein retention*. *Embo J*, 1995. **14**(19): p. 4695-704.
34. Bonfanti, L., et al., *Procollagen traverses the Golgi stack without leaving the lumen of cisternae: evidence for cisternal maturation*. *Cell*, 1998. **95**(7): p. 993-1003.
35. Thudichum, J., *A Treatise on the Chemical Constitution of the Brain*. 1884, London: Bailliere, Tindall and Cox.
36. Gahmberg, C.G. and S.I. Hakomori, *External labeling of cell surface galactose and galactosamine in glycolipid and glycoprotein of human erythrocytes*. *J Biol Chem*, 1973. **248**(12): p. 4311-7.
37. Karlsson, K.-A., ed., ed. D. Chapman. Vol. 4. 1982, Academic: New York. 1-74.
38. Hakomori, S., *Glycosynapses: microdomains controlling carbohydrate-dependent cell adhesion and signaling*. *An Acad Bras Cienc*, 2004. **76**(3): p. 553-72.
39. Korade, Z. and A.K. Kenworthy, *Lipid rafts, cholesterol, and the brain*. *Neuropharmacology*, 2008. **55**(8): p. 1265-73.
40. Iwabuchi, K., K. Handa, and S. Hakomori, *Separation of "glycosphingolipid signaling domain" from caveolin-containing membrane fraction in mouse melanoma B16 cells and its role in cell adhesion coupled with signaling*. *J Biol Chem*, 1998. **273**(50): p. 33766-73.
41. Hakomori, S.I., *Structure and function of glycosphingolipids and sphingolipids: recollections and future trends*. *Biochim Biophys Acta*, 2008. **1780**(3): p. 325-46.

42. Landsteiner, K., *Zur kenntniss der antifermentativen, lytischen and agglutinierenden Wirkungen des blutserums und der lymphhe*. Zbl Bakt, 1900. **27**: p. 357-366.
43. Morgan, W.T. and W.M. Watkins, *The inhibition of the haemagglutinins in plant seeds by human blood group substances and simple sugars*. Br J Exp Pathol, 1953. **34**(1): p. 94-103.
44. Watkins, W.M. and W.T. Morgan, *Further observations on the inhibition of blood-group specific serological reactions by simple sugars of known structure*. Vox Sang, 1962. **7**: p. 129-50.
45. Clausen, H. and S. Hakomori, *ABH and related histo-blood group antigens; immunochemical differences in carrier isotypes and their distribution*. Vox Sang, 1989. **56**(1): p. 1-20.
46. Hansson, G.C., *Structural aspects of blood group glycosphingolipids in the gastrointestinal tract*. Adv Exp Med Biol, 1988. **228**: p. 465-94.
47. Holgersson, J., M.E. Breimer, and B.E. Samuelsson, *Basic biochemistry of cell surface carbohydrates and aspects of the tissue distribution of histo-blood group ABH and related glycosphingolipids*. APMIS Suppl, 1992. **27**: p. 18-27.
48. Breimer, M.E., et al., *Blood group type glycosphingolipids from the small intestine of different animals analysed by mass spectrometry and thin-layer chromatography. A note on species diversity*. J Biochem, 1981. **90**(3): p. 589-609.
49. Yamakawa, T., R. Irie, and M. Iwanaga, *The chemistry of lipid of posthemolytic residue or stroma of erythrocytes: IX. Silicic acid chromatography of mammalian stroma glycolipids* J. Biochem., 1960. **48**(4): p. 490-507.
50. Breimer, M.E., et al., *Human blood group A-positive and -negative strains of rat. Chemical basis as shown by fucolipids of small intestine*. FEBS Lett, 1980. **114**(1): p. 51-6.
51. Adams, E.P. and G.M. Gray, *The carbohydrate structures of the neutral ceramide glycolipids in kidneys of different mouse strains with special reference to the ceramide dihexosides*. Chem Phys Lipids, 1968. **2**(2): p. 147-55.
52. Hamanaka, S., S. Handa, and T. Yamakawa, *Ganglioside compositions of erythrocytes from various strains of inbred mice. Occurrence of sialosylgalactosylceramide in red blood cells of inbred mice*. J Biochem, 1979. **86**(5): p. 1623-6.
53. Oriol, R., et al., *Genetic regulation of the expression of ABH and Lewis antigens in tissues*. APMIS Suppl, 1992. **27**: p. 28-38.
54. Ravn, V. and E. Dabelsteen, *Tissue distribution of histo-blood group antigens*. Apmis, 2000. **108**(1): p. 1-28.
55. Oriol, R., et al., *Major oligosaccharide epitopes found in tissues of 23 animal species, potential donors for organ xenotransplantation*. Transplant Proc, 1996. **28**(2): p. 794.
56. Svennerholm, L., et al., *Large alterations in ganglioside and neutral glycosphingolipid patterns in brains from cases with infantile neuronal ceroid lipofuscinosis/polyunsaturated fatty acid lipidosis*. J Neurochem, 1987. **49**(6): p. 1772-83.
57. Breimer, M.E., et al., *Glycosphingolipids of rat tissues. Different composition of epithelial and nonepithelial cells of small intestine*. J Biol Chem, 1982. **257**(1): p. 557-68.
58. Breimer, M.E., et al., *Glycosphingolipids and the differentiation of intestinal epithelium*. Exp Cell Res, 1981. **135**(1): p. 1-13.
59. Fredman, P., *Glycosphingolipid tumor antigens*. Adv Lipid Res, 1993. **25**: p. 213-34.
60. Sakakibara, N., et al., *Distinctive glycolipid patterns in Wilms' tumor and renal cell carcinoma*. Cancer Lett, 1991. **57**(3): p. 187-92.

61. Hakomori, S.I. and W.T. Murakami, *Glycolipids of hamster fibroblasts and derived malignant-transformed cell lines*. Proc Natl Acad Sci U S A, 1968. **59**(1): p. 254-61.
62. Magnani, J.L., et al., *A monoclonal antibody-defined antigen associated with gastrointestinal cancer is a ganglioside containing sialylated lacto-N-fucopentaose II*. J Biol Chem, 1982. **257**(23): p. 14365-9.
63. Fukushima, K., et al., *Characterization of sialosylated Lewisx as a new tumor-associated antigen*. Cancer Res, 1984. **44**(11): p. 5279-85.
64. Stroud, M.R., et al., *Extended type 1 chain glycosphingolipids: dimeric Lea (III4V4Fuc2Lc6) as human tumor-associated antigen*. J Biol Chem, 1991. **266**(13): p. 8439-46.
65. Watanabe, M., et al., *In vitro and in vivo antitumor effects of murine monoclonal antibody NCC-ST-421 reacting with dimeric Le(a) (Le(a)/Le(a)) epitope*. Cancer Res, 1991. **51**(8): p. 2199-204.
66. Misonou, Y., et al., *Comprehensive Clinico-Glycomic Study of 16 Colorectal Cancer Specimens: Elucidation of Aberrant Glycosylation and Its Mechanistic Causes in Colorectal Cancer Cells*. J Proteome Res, 2009.
67. Fukushi, Y., et al., *Novel fucolipids accumulating in human adenocarcinoma. III. A hybridoma antibody (FH6) defining a human cancer-associated difucoganglioside (VI3NeuAcV3III3Fuc2nLc6)*. J Biol Chem, 1984. **259**(16): p. 10511-7.
68. Hakkinen, I., *A-like blood group antigen in gastric cancer cells of patients in blood groups Q or B*. J Natl Cancer Inst, 1970. **44**(5): p. 1183-93.
69. Gold, P. and S.O. Freedman, *Specific carcinoembryonic antigens of the human digestive system*. J Exp Med, 1965. **122**(3): p. 467-81.
70. Hakomori, S., S.M. Wang, and W.W. Young, Jr., *Isoantigenic expression of Forssman glycolipid in human gastric and colonic mucosa: its possible identity with "A-like antigen" in human cancer*. Proc Natl Acad Sci U S A, 1977. **74**(7): p. 3023-7.
71. Carroll, L., *Through the looking glass*. 1871: Macmillan. 224.
72. Varki, A., *Nothing in glycobiology makes sense, except in the light of evolution*. Cell, 2006. **126**(5): p. 841-5.
73. Ichikawa, S., et al., *A mouse B16 melanoma mutant deficient in glycolipids*. Proc Natl Acad Sci U S A, 1994. **91**(7): p. 2703-7.
74. Yamashita, T., et al., *A vital role for glycosphingolipid synthesis during development and differentiation*. Proc Natl Acad Sci U S A, 1999. **96**(16): p. 9142-7.
75. Jennemann, R., et al., *Cell-specific deletion of glucosylceramide synthase in brain leads to severe neural defects after birth*. Proc Natl Acad Sci U S A, 2005. **102**(35): p. 12459-64.
76. Henry, S., R. Oriol, and B. Samuelsson, *Lewis histo-blood group system and associated secretory phenotypes*. Vox Sang, 1995. **69**(3): p. 166-82.
77. Clausen, H., et al., *Blood group A determinants with mono- and difucosyl type 1 chain in human erythrocyte membranes*. Biochemistry, 1985. **24**(14): p. 3578-86.
78. Breimer, M.E., K.A. Karlsson, and B.E. Samuelsson, *Characterization of a human intestinal difucosyl heptaglycosylceramide with a blood group B determinant and a type 1 carbohydrate chain*. J Biol Chem, 1982. **257**(2): p. 1079-85.
79. Lindstrom, K., et al., *Non-acid glycosphingolipid expression in plasma of an A1 Le(a-b+) secretor human individual: identification of an ALeb heptaglycosylceramide as major blood group component*. J Biochem, 1992. **111**(3): p. 337-45.
80. Lindstrom, K., et al., *Blood group glycosphingolipid expression in kidney of an individual with the rare blood group A1 Le(a-b+) p phenotype: absence of blood group structures based on the globoseries*. Glycoconj J, 1996. **13**(2): p. 307-13.

81. Simpson, M.A., et al., *Infantile-onset symptomatic epilepsy syndrome caused by a homozygous loss-of-function mutation of GM3 synthase*. Nat Genet, 2004. **36**(11): p. 1225-9.
82. Zebda, N., et al., *Deficiency of ganglioside biosynthesis in metastatic human melanoma cells: relevance of CMP-NeuAc:LacCer alpha 2-3 sialyltransferase (GM3 synthase)*. FEBS Lett, 1995. **362**(2): p. 161-4.
83. Bosio, A., E. Binczek, and W. Stoffel, *Functional breakdown of the lipid bilayer of the myelin membrane in central and peripheral nervous system by disrupted galactocerebroside synthesis*. Proc Natl Acad Sci U S A, 1996. **93**(23): p. 13280-5.
84. Coetzee, T., et al., *Myelination in the absence of galactocerebroside and sulfatide: normal structure with abnormal function and regional instability*. Cell, 1996. **86**(2): p. 209-19.
85. Dupree, J.L., J.A. Girault, and B. Popko, *Axo-glial interactions regulate the localization of axonal paranodal proteins*. J Cell Biol, 1999. **147**(6): p. 1145-52.
86. Yamashita, T., et al., *Enhanced insulin sensitivity in mice lacking ganglioside GM3*. Proc Natl Acad Sci U S A, 2003. **100**(6): p. 3445-9.
87. Falk, P.G., et al., *Expression of a human alpha-1,3/4-fucosyltransferase in the pit cell lineage of FVB/N mouse stomach results in production of Leb-containing glycoconjugates: a potential transgenic mouse model for studying Helicobacter pylori infection*. Proc Natl Acad Sci U S A, 1995. **92**(5): p. 1515-9.
88. Fagerberg, D., et al., *Novel Leb-like Helicobacter pylori-binding glycosphingolipid created by the expression of human alpha-1,3/4-fucosyltransferase in FVB/N mouse stomach*. Glycobiology, 2009. **19**(2): p. 182-91.
89. Kawai, H., et al., *Mice expressing only monosialoganglioside GM3 exhibit lethal audiogenic seizures*. J Biol Chem, 2001. **276**(10): p. 6885-8.
90. Inoue, M., et al., *Refractory skin injury in complex knock-out mice expressing only the GM3 ganglioside*. J Biol Chem, 2002. **277**(33): p. 29881-8.
91. Cooper, D.K., et al., eds. *Xenotransplantation*. 1991, Springer-Verlag: Heidelberg.
92. Calne, R.Y., *Organ transplantation between widely disparate species*. Transplant Proc, 1970. **2**(4): p. 550-6.
93. Stussi, G., et al., *ABO-incompatible allotransplantation as a basis for clinical xenotransplantation*. Xenotransplantation, 2006. **13**(5): p. 390-9.
94. Angstrom, J., et al., *Structural characterization of glycolipids of rat small intestine having one to eight hexoses in a linear sequence*. Arch Biochem Biophys, 1982. **213**(2): p. 708-25.
95. Bouhours, D., et al., *A novel glycosphingolipid expressed in pig kidney: Gal alpha 1-3Lewis(x) hexaglycosylceramide*. Glycoconj J, 1997. **14**(1): p. 29-38.
96. Rydberg, L., et al., *alpha-Gal epitopes in animal tissue glycoproteins and glycolipids*. Subcell Biochem, 1999. **32**: p. 107-25.
97. Oriol, R., et al., *Carbohydrate antigens of pig tissues reacting with human natural antibodies as potential targets for hyperacute vascular rejection in pig-to-man organ xenotransplantation*. Transplantation, 1993. **56**(6): p. 1433-42.
98. Galili, U., et al., *Man, apes, and Old World monkeys differ from other mammals in the expression of alpha-galactosyl epitopes on nucleated cells*. J Biol Chem, 1988. **263**(33): p. 17755-62.
99. Galili, U., *Interaction of the natural anti-Gal antibody with alpha-galactosyl epitopes: a major obstacle for xenotransplantation in humans*. Immunol Today, 1993. **14**(10): p. 480-2.
100. Galili, U., et al., *One percent of human circulating B lymphocytes are capable of producing the natural anti-Gal antibody*. Blood, 1993. **82**(8): p. 2485-93.



101. Kobayashi, T., et al., *Comparative study of the efficacy of removal of anti-ABO and anti-gal antibodies by double filtration plasmapheresis*. *Xenotransplantation*, 2000. **7**(2): p. 101-8.
102. Rydberg, L., et al., *Studies on the removal of anti-pig xenoantibodies in the human by plasmapheresis/immunoabsorption*. *Xenotransplantation*, 1995. **2**(4): p. 253-63.
103. Leventhal, J.R., et al., *Removal of baboon and human antiporcine IgG and IgM natural antibodies by immunoabsorption. Results of in vitro and in vivo studies*. *Transplantation*, 1995. **59**(2): p. 294-300.
104. Xu, Y., et al., *Removal of anti-porcine natural antibodies from human and nonhuman primate plasma in vitro and in vivo by a Gal $\alpha$ 1-3Gal $\beta$ 1-4 $\beta$ Glc-X immunoaffinity column*. *Transplantation*, 1998. **65**(2): p. 172-9.
105. Cairns, T., et al., *Inhibition of the pig to human xenograft reaction, using soluble Gal $\alpha$ 1-3Gal and Gal $\alpha$ 1-3Gal $\beta$ 1-4GlcNAc*. *Transplantation*, 1995. **60**(11): p. 1202-7.
106. Galili, U. and K.L. Matta, *Inhibition of anti-Gal IgG binding to porcine endothelial cells by synthetic oligosaccharides*. *Transplantation*, 1996. **62**(2): p. 256-62.
107. Candinas, D., et al., *Effect of repetitive high-dose treatment with soluble complement receptor type 1 and cobra venom factor on discordant xenograft survival*. *Transplantation*, 1996. **62**(3): p. 336-42.
108. Cohnen, S., et al., *Down-regulation of Gal $\alpha$ (1,3)Gal expression by alpha1,2-fucosyltransferase: further characterization of alpha1,2-fucosyltransferase transgenic mice*. *Transplantation*, 1997. **64**(3): p. 495-500.
109. McKenzie, I.F., et al., *Fucosyl transferase (H) transgenic heart transplants to Gal $\alpha$ -mice*. *Transplantation*, 2000. **70**(8): p. 1205-9.
110. Sharma, A., et al., *Reduction in the level of Gal $\alpha$ (1,3)Gal in transgenic mice and pigs by the expression of an alpha(1,2)fucosyltransferase*. *Proc Natl Acad Sci U S A*, 1996. **93**(14): p. 7190-5.
111. Costa, C., et al., *Expression of the human alpha1,2-fucosyltransferase in transgenic pigs modifies the cell surface carbohydrate phenotype and confers resistance to human serum-mediated cytolysis*. *Faseb J*, 1999. **13**(13): p. 1762-73.
112. Osman, N., et al., *Combined transgenic expression of alpha-galactosidase and alpha1,2-fucosyltransferase leads to optimal reduction in the major xenoepitope Gal $\alpha$ (1,3)Gal*. *Proc Natl Acad Sci U S A*, 1997. **94**(26): p. 14677-82.
113. Diamond, L.E., et al., *A human CD46 transgenic pig model system for the study of discordant xenotransplantation*. *Transplantation*, 2001. **71**(1): p. 132-42.
114. Zhou, C.Y., et al., *Transgenic pigs expressing human CD59, in combination with human membrane cofactor protein and human decay-accelerating factor*. *Xenotransplantation*, 2005. **12**(2): p. 142-8.
115. Dwyer, K.M., P.J. Cowan, and A.J. d'Apice, *Xenotransplantation: past achievements and future promise*. *Heart Lung Circ*, 2002. **11**(1): p. 32-41.
116. Tearle, R.G., et al., *The alpha-1,3-galactosyltransferase knockout mouse. Implications for xenotransplantation*. *Transplantation*, 1996. **61**(1): p. 13-9.
117. Tanemura, M. and U. Galili, *Differential expression of alpha-Gal epitopes on pig and mouse organs*. *Transplant Proc*, 2000. **32**(5): p. 843.
118. Phelps, C.J., et al., *Production of alpha 1,3-galactosyltransferase-deficient pigs*. *Science*, 2003. **299**(5605): p. 411-4.
119. Kolber-Simonds, D., et al., *Production of alpha-1,3-galactosyltransferase null pigs by means of nuclear transfer with fibroblasts bearing loss of heterozygosity mutations*. *Proc Natl Acad Sci U S A*, 2004. **101**(19): p. 7335-40.

120. Yamada, K., et al., *Marked prolongation of porcine renal xenograft survival in baboons through the use of alpha1,3-galactosyltransferase gene-knockout donors and the cotransplantation of vascularized thymic tissue*. Nat Med, 2005. **11**(1): p. 32-4.
121. Kuwaki, K., et al., *Heart transplantation in baboons using alpha1,3-galactosyltransferase gene-knockout pigs as donors: initial experience*. Nat Med, 2005. **11**(1): p. 29-31.
122. McGregor, C.G., et al., *Cardiac xenotransplantation: recent preclinical progress with 3-month median survival*. J Thorac Cardiovasc Surg, 2005. **130**(3): p. 844-51.
123. McGregor, C.G., et al., *Cardiac xenotransplantation: progress toward the clinic*. Transplantation, 2004. **78**(11): p. 1569-75.
124. Houser, S.L., et al., *Thrombotic microangiopathy and graft arteriopathy in pig hearts following transplantation into baboons*. Xenotransplantation, 2004. **11**(5): p. 416-25.
125. Buhler, L., et al., *An investigation of the specificity of induced anti-pig antibodies in baboons*. Xenotransplantation, 2003. **10**(1): p. 88-93.
126. Lee, E.U., J. Roth, and J.C. Paulson, *Alteration of terminal glycosylation sequences on N-linked oligosaccharides of Chinese hamster ovary cells by expression of beta-galactoside alpha 2,6-sialyltransferase*. J Biol Chem, 1989. **264**(23): p. 13848-55.
127. Potvin, B., et al., *Transfection of a human alpha-(1,3)fucosyltransferase gene into Chinese hamster ovary cells. Complications arise from activation of endogenous alpha-(1,3)fucosyltransferases*. J Biol Chem, 1990. **265**(3): p. 1615-22.
128. Lofling, J.C., E. Hauzenberger, and J. Holgersson, *Absorption of anti-blood group A antibodies on P-selectin glycoprotein ligand-1/immunoglobulin chimeras carrying blood group A determinants: core saccharide chain specificity of the Se and H gene encoded alpha1,2 fucosyltransferases in different host cells*. Glycobiology, 2002. **12**(3): p. 173-82.
129. Smith, D.F., et al., *Transfer and expression of a murine UDP-Gal:beta-D-Gal-alpha 1,3-galactosyltransferase gene in transfected Chinese hamster ovary cells. Competition reactions between the alpha 1,3-galactosyltransferase and the endogenous alpha 2,3-sialyltransferase*. J Biol Chem, 1990. **265**(11): p. 6225-34.
130. Liu, J., A. Weintraub, and J. Holgersson, *Multivalent Galalpha1,3Gal-substitution makes recombinant mucin-immunoglobulins efficient absorbers of anti-pig antibodies*. Xenotransplantation, 2003. **10**(2): p. 149-63.
131. Backstrom, M., et al., *Recombinant MUC1 mucin with a breast cancer-like O-glycosylation produced in large amounts in Chinese-hamster ovary cells*. Biochem J, 2003. **376**(Pt 3): p. 677-86.
132. Oh-Eda, M., et al., *Overexpression of the Golgi-localized enzyme alpha-mannosidase IIx in Chinese hamster ovary cells results in the conversion of hexamannosyl-N-acetylchitobiose to tetramannosyl-N-acetylchitobiose in the N-glycan-processing pathway*. Eur J Biochem, 2001. **268**(5): p. 1280-8.
133. Marshall, B.J. and J.R. Warren, *Unidentified curved bacilli in the stomach of patients with gastritis and peptic ulceration*. Lancet, 1984. **1**(8390): p. 1311-5.
134. Dunn, B.E., H. Cohen, and M.J. Blaser, *Helicobacter pylori*. Clin Microbiol Rev, 1997. **10**(4): p. 720-41.
135. Peek, R.M., Jr. and M.J. Blaser, *Helicobacter pylori and gastrointestinal tract adenocarcinomas*. Nat Rev Cancer, 2002. **2**(1): p. 28-37.
136. Montecucco, C. and R. Rappuoli, *Living dangerously: how Helicobacter pylori survives in the human stomach*. Nat Rev Mol Cell Biol, 2001. **2**(6): p. 457-66.
137. Mahdavi, J., et al., *Helicobacter pylori SabA adhesin in persistent infection and chronic inflammation*. Science, 2002. **297**(5581): p. 573-8.

138. Ilver, D., et al., *Helicobacter pylori* adhesin binding fucosylated histo-blood group antigens revealed by retagging. *Science*, 1998. **279**(5349): p. 373-7.
139. Boren, T., et al., *Attachment of Helicobacter pylori to human gastric epithelium mediated by blood group antigens*. *Science*, 1993. **262**(5141): p. 1892-5.
140. Hakomori, S.-I., *Chemistry of glycosphingolipids*, in *Sphingolipid biochemistry*, J.N. Kanfer and S.-I. Hakomori, Editors. 1983, Plenum Press: New York. p. 1-165.
141. Karlsson, K.A., *Preparation of total nonacid glycolipids for overlay analysis of receptors for bacteria and viruses and for other studies*. *Methods Enzymol*, 1987. **138**: p. 212-20.
142. Miller-Podraza, H., C. Andersson, and K.A. Karlsson, *New method for the isolation of polyglycosylceramides from human erythrocyte membranes*. *Biochim Biophys Acta*, 1993. **1168**(3): p. 330-9.
143. Leonardsson, I., et al., *Isolation and partial characterization of Gal alpha-containing polyglycosylceramides from porcine tissues*. *Xenotransplantation*, 2004. **11**(1): p. 97-100.
144. Koscielak, J., et al., *Isolation and characterization of poly(glycosyl)ceramides (megalogycolipids) with A, H and I blood-group activities*. *Eur J Biochem*, 1976. **71**(1): p. 9-18.
145. Breimer, M.E., K.A. Karlsson, and B.E. Samuelsson, *Characterization of a blood group H type pentaglycosylceramide of human pancreas based on a type I carbohydrate chain*. *J Biol Chem*, 1981. **256**(8): p. 3810-6.
146. Schnaar, R.L. and L.K. Needham, *Thin-layer chromatography of glycosphingolipids*. *Methods Enzymol*, 1994. **230**: p. 371-89.
147. Svennerholm, L., *Chromatographic Separation of Human Brain Gangliosides*. *J Neurochem*, 1963. **10**: p. 613-23.
148. Bhavanandan, V.P. and M. Sheykhnazari, *Adaptation of the periodate-resorcinol method for determination of sialic acids to a microassay using microtiter plate reader*. *Anal Biochem*, 1993. **213**(2): p. 438-40.
149. Magnani, J.L., D.F. Smith, and V. Ginsburg, *Detection of gangliosides that bind cholera toxin: direct binding of 125I-labeled toxin to thin-layer chromatograms*. *Anal Biochem*, 1980. **109**(2): p. 399-402.
150. Manimala, J.C., et al., *High-throughput carbohydrate microarray profiling of 27 antibodies demonstrates widespread specificity problems*. *Glycobiology*, 2007. **17**(8): p. 17C-23C.
151. Evans, M.S., et al., *Persistent organic pollutants and metals in the freshwater biota of the Canadian Subarctic and Arctic: an overview*. *Sci Total Environ*, 2005. **351-352**: p. 94-147.
152. Abrahamson, S., S. Ställberg-Stenhagen, and E. Stenhagen, *The higher saturated branched chain fatty acids*, ed. R. Holman. 1962, Oxford: Pergamon Press.
153. Samuelsson, B.E., W. Pimlott, and K.A. Karlsson, *Mass spectrometry of mixtures of intact glycosphingolipids*. *Methods Enzymol*, 1990. **193**: p. 623-46.
154. Karlsson, K.A., *On the chemistry and occurrence of sphingolipid long-chain bases*. *Chem Phys Lipids*, 1970. **5**(1): p. 6-43.
155. Hakomori, S., *A Rapid Permethylation of Glycolipid, and Polysaccharide Catalyzed by Methylsulfinyl Carbanion in Dimethyl Sulfoxide*. *J Biochem*, 1964. **55**: p. 205-8.
156. Karlsson, K.A., *Carbohydrate composition and sequence analysis of a derivative of brain disialoganglioside by mass spectrometry, with molecular weight ions at m-e 2245. Potential use in the specific microanalysis of cell surface components*. *Biochemistry*, 1974. **13**(18): p. 3643-7.

157. Ito, M. and T. Yamagata, *Purification and characterization of glycosphingolipid-specific endoglycosidases (endoglycoceramidasases) from a mutant strain of Rhodococcus sp. Evidence for three molecular species of endoglycoceramidase with different specificities.* J Biol Chem, 1989. **264**(16): p. 9510-9.
158. Falk, K.E., K.A. Karlsson, and B.E. Samuelsson, *Proton nuclear magnetic resonance analysis of anomeric structure of glycosphingolipids. The globo-series (one to five sugars).* Arch Biochem Biophys, 1979. **192**(1): p. 164-76.
159. Falk, K.E., K.A. Karlsson, and B.E. Samuelsson, *Proton nuclear magnetic resonance analysis of anomeric structure of glycosphingolipids. Lewis-active and Lewis-like substances.* Arch Biochem Biophys, 1979. **192**(1): p. 191-202.
160. Falk, K.E., K.A. Karlsson, and B.E. Samuelsson, *Proton nuclear magnetic resonance analysis of anomeric structure of glycosphingolipids. Blood group ABH-active substances.* Arch Biochem Biophys, 1979. **192**(1): p. 177-90.
161. Dabrowski, J., P. Hanfland, and H. Egge, *Structural analysis of glycosphingolipids by high-resolution <sup>1</sup>H nuclear magnetic resonance spectroscopy.* Biochemistry, 1980. **19**(24): p. 5652-8.
162. Angstrom, J., et al., *Default biosynthesis pathway for blood group-related glycolipids in human small intestine as defined by structural identification of linear and branched glycosylceramides in a group O Le(a-b-) nonsecretor.* Glycobiology, 2004. **14**(1): p. 1-12.
163. Jiménez-Barbero, J. and T. Peters, eds. *NMR spectroscopy of glycoconjugates.* 2003, GmbH & Co., KGaA: Weinheim.
164. Gasa, S., T. Mitsuyama, and A. Makita, *Proton nuclear magnetic resonance of neutral and acidic glycosphingolipids.* J Lipid Res, 1983. **24**(2): p. 174-82.
165. Smith, D.M., et al., *Blood groups and transfusions in pigs.* Xenotransplantation, 2006. **13**(3): p. 186-94.
166. Schroeder, C., et al., *Hyperacute rejection is attenuated in GalT knockout swine lungs perfused ex vivo with human blood.* Transplant Proc, 2005. **37**(1): p. 512-3.
167. Sharma, A., et al., *Pig cells that lack the gene for alpha1-3 galactosyltransferase express low levels of the gal antigen.* Transplantation, 2003. **75**(4): p. 430-6.
168. Milland, J., et al., *The molecular basis for galalpha(1,3)gal expression in animals with a deletion of the alpha1,3galactosyltransferase gene.* J Immunol, 2006. **176**(4): p. 2448-54.
169. Backer, A.E., et al., *Rapid and sensitive GC/MS characterization of glycolipid released Galalpha1,3Gal-terminated oligosaccharides from small organ specimens of a single pig.* Glycobiology, 1998. **8**(6): p. 533-45.
170. Hallberg, E.C., J. Holgersson, and B.E. Samuelsson, *Glycosphingolipid expression in pig aorta: identification of possible target antigens for human natural antibodies.* Glycobiology, 1998. **8**(7): p. 637-49.
171. Bouhours, D., et al., *Two novel isoneolacto-undecaglycosylceramides carrying Galalpha1-->3Lewis(x) on the 6-linked antenna and N-acetylneuraminic acidalpha2-->3 or Galactose alpha1-->3 on the 3-linked antenna, expressed in porcine kidney.* Glycoconj J, 1998. **15**(10): p. 1001-16.
172. Holgersson, J., et al., *Structural characterization of non-acid glycosphingolipids in kidneys of single blood group O and A pigs.* J Biochem, 1990. **108**(5): p. 766-77.
173. Chien, J.L., S.C. Li, and Y.T. Li, *Isolation and characterization of a heptaglycosylceramide from bovine erythrocyte membranes.* J Lipid Res, 1979. **20**(5): p. 669-73.
174. McKibbin, J.M., *The composition of the glycolipids in dog intestine.* Biochemistry, 1969. **8**(2): p. 679-85.

175. Smith, E.L., et al., *Characterization of dog small intestinal fucolipids with human blood group H activity*. *Biochemistry*, 1975. **14**(15): p. 3370-6.
176. Suzuki, C., A. Makita, and Z. Yosizawa, *Glycolipids isolated from porcine intestine*. *Arch Biochem Biophys*, 1968. **127**(1): p. 140-9.
177. Breimer, M.E., et al., *Structural identification of two ten-sugar branched chain glycosphingolipids of blood group H type present in epithelial cells of rat small intestine*. *J Biol Chem*, 1982. **257**(1): p. 50-9.
178. Breimer, M.E., et al., *Demonstration of complexity of the glycosphingolipid fraction of rat small intestine*. *Biochem Biophys Res Commun*, 1980. **95**(1): p. 416-22.
179. Falk, K.E., et al., *Specific pattern of glycosphingolipids enriched in a mucosa scraping of human small intestine*. *FEBS Lett*, 1979. **101**(2): p. 273-6.
180. Hanfland, P., et al., *Isolation and characterization of an I-active ceramide decasaccharide from rabbit erythrocyte membranes*. *Biochemistry*, 1981. **20**(18): p. 5310-9.
181. Dabrowski, U., et al., *Immunochemistry of I/i-active oligo- and polyglycosylceramides from rabbit erythrocyte membranes. Determination of branching patterns of a ceramide pentadecasaccharide by <sup>1</sup>H nuclear magnetic resonance*. *J Biol Chem*, 1984. **259**(12): p. 7648-51.
182. Milland, J., D. Christiansen, and M.S. Sandrin, *Alpha1,3-galactosyltransferase knockout pigs are available for xenotransplantation: are glycosyltransferases still relevant?* *Immunol Cell Biol*, 2005. **83**(6): p. 687-93.
183. Kannagi, R., M.N. Fukuda, and S. Hakomori, *A new glycolipid antigen isolated from human erythrocyte membranes reacting with antibodies directed to globo-N-tetraosylceramide (globoside)*. *J Biol Chem*, 1982. **257**(8): p. 4438-42.
184. Thorn, J.J., et al., *Structural characterization of x2 glycosphingolipid, its extended form, and its sialosyl derivatives: accumulation associated with the rare blood group p phenotype*. *Biochemistry*, 1992. **31**(28): p. 6509-17.
185. Magnusson, S., et al., *Ganglioside xenoantigens in pig lymphocytes and aorta*. *Transplant Proc*, 2000. **32**(5): p. 848-50.
186. Magnusson, S., et al., *Release of pig leukocytes during pig kidney perfusion and characterization of pig lymphocyte carbohydrate xenoantigens*. *Xenotransplantation*, 2003. **10**(5): p. 432-45.
187. Merrick, J.M., K. Zadarlik, and F. Milgrom, *Characterization of the Hanganutziu-Deicher (serum-sickness) antigen as gangliosides containing n-glycolylneuraminic acid*. *Int Arch Allergy Appl Immunol*, 1978. **57**(5): p. 477-80.
188. Keusch, J.J., et al., *Expression cloning of a new member of the ABO blood group glycosyltransferases, iGb3 synthase, that directs the synthesis of isoglobo-glycosphingolipids*. *J Biol Chem*, 2000. **275**(33): p. 25308-14.
189. Ostrander, G.K., et al., *Isolation and characterization of four major neutral glycosphingolipids from the liver of the English sole (Parophrys vetulus). Presence of a novel branched lacto-ganglio-iso-globo hybrid structure*. *J Biol Chem*, 1988. **263**(35): p. 18716-25.
190. Sung, S.S. and C.C. Sweeley, *The structure of canine intestinal trihexosylceramide*. *Biochim Biophys Acta*, 1979. **575**(2): p. 295-98.
191. Yamamoto, H., et al., *Isolation and characterization of a novel Forssman active acidic glycosphingolipid with branched isoglobo-, ganglio-, and neolacto-series hybrid sugar chains*. *J Biochem*, 1999. **125**(5): p. 923-30.
192. Slomiany, B.L., A. Slomiany, and M.I. Horowitz, *Characterization of blood-group-H-active ceramide tetrasaccharide from hog-stomach mucosa*. *Eur J Biochem*, 1974. **43**(1): p. 161-5.

193. Sadahira, Y., T. Yasuda, and T. Kimoto, *Regulation of Forssman antigen expression during maturation of mouse stromal macrophages in haematopoietic foci*. Immunology, 1991. **73**(4): p. 498-504.
194. Stinnakre, M.G., et al., *Expression of Forssman antigen in the post-implantation mouse embryo*. J Embryol Exp Morphol, 1981. **61**: p. 117-31.
195. von Kleist, R., et al., *Modulation of Forssman glycosphingolipid expression by murine macrophages: coinduction with class II MHC antigen by the lymphokines IL4 and IL6*. Immunobiology, 1990. **180**(4-5): p. 405-18.
196. Willison, K.R. and P.L. Stern, *Expression of a Forssman antigenic specificity in the preimplantation mouse embryo*. Cell, 1978. **14**(4): p. 785-93.
197. Strokan, V., et al., *Characterisation of human natural anti-sheep xenoantibodies*. Xenotransplantation, 1998. **5**(2): p. 111-21.
198. Holgersson, J., et al., *Blood group type glycosphingolipids of human kidneys. Structural characterization of extended globo-series compounds*. Glycoconj J, 1991. **8**(5): p. 424-33.
199. Ezzelarab, M., et al., *Extended coagulation profiles of healthy baboons and of baboons rejecting GT-KO pig heart grafts*. Xenotransplantation, 2006. **13**(6): p. 522-8.
200. Lynch, R.J. and J.L. Platt, *Accommodation in organ transplantation*. Curr Opin Organ Transplant, 2008. **13**(2): p. 165-70.
201. Gustafsson, A., et al., *Carbohydrate-dependent inhibition of Helicobacter pylori colonization using porcine milk*. Glycobiology, 2006. **16**(1): p. 1-10.
202. Huang, M.C., et al., *The alpha (1,3)-fucosyltransferase Fuc-TIV, but not Fuc-TVII, generates sialyl Lewis X-like epitopes preferentially on glycolipids*. J Biol Chem, 2002. **277**(49): p. 47786-95.
203. Howard, D.R., et al., *The GDP-fucose:N-acetylglucosaminide 3-alpha-L-fucosyltransferases of LEC11 and LEC12 Chinese hamster ovary mutants exhibit novel specificities for glycolipid substrates*. J Biol Chem, 1987. **262**(35): p. 16830-7.
204. Campbell, C. and P. Stanley, *Regulatory mutations in CHO cells induce expression of the mouse embryonic antigen SSEA-1*. Cell, 1983. **35**(1): p. 303-9.
205. Hartel-Schenk, S., et al., *Distribution of glycosyltransferases among Golgi apparatus subfractions from liver and hepatomas of the rat*. Biochim Biophys Acta, 1991. **1115**(2): p. 108-22.
206. Sandrin, M.S., et al., *Enzymatic remodelling of the carbohydrate surface of a xenogenic cell substantially reduces human antibody binding and complement-mediated cytotoxicity*. Nat Med, 1995. **1**(12): p. 1261-7.
207. Bjork, S., et al., *Structures of blood group glycosphingolipids of human small intestine. A relation between the expression of fucolipids of epithelial cells and the ABO, Le and Se phenotype of the donor*. J Biol Chem, 1987. **262**(14): p. 6758-65.